

# InDesign Publishing Engine 1.0 Reference Manual

*Complete reference to Sitecore Adaptive Print Studio*

## Table of Contents

|            |  |    |
|------------|--|----|
| Chapter 1  | Overview . . . . .   | 3  |
| Chapter 2  | Introduction . . . . .   | 4  |
|            | 2.1 Process overview . . . . .                                     | 5  |
|            | 2.2 Sample documents . . . . .                                     | 5  |
| Chapter 3  | Document elements . . . . .  | 7  |
|            | 3.1 Project element . . . . .                                      | 8  |
|            | 3.2 Book element . . . . .   | 8  |
|            | 3.3 Document element . . . . .                                     | 11 |
| Chapter 4  | Page elements . . . . .  | 13 |
|            | 4.1 Page element . . . . .   | 14 |
|            | 4.2 Textframe element . . . . .                                    | 15 |
|            | 4.3 ImageFrame element . . . . .                                   | 18 |
|            | 4.4 Image element . . . . .  | 20 |
|            | 4.5 Ellipse element . . . . .                                      | 22 |
|            | 4.6 Rectangle element . . . . .                                    | 25 |
|            | 4.7 Line element . . . . .   | 27 |
|            | 4.7.1 LinePoint element . . . . .                                  | 29 |
| Chapter 5  | Content elements . . . . .   | 31 |
|            | 5.1 ParagraphStyle element . . . . .                               | 32 |
|            | 5.2 CharacterStyle element . . . . .                               | 32 |
|            | 5.3 SpecialCharacter element . . . . .                             | 33 |
|            | 5.4 InsertVar element . . . . .                                    | 33 |
|            | 5.4.1 Using the InsertVar element in a table of contents . . . . . | 33 |
|            | 5.4.2 Using the InsertVar element in an index . . . . .            | 39 |
| Chapter 6  | Tables . . . . .   | 42 |
|            | 6.1 Table element . . . . .  | 43 |
|            | 6.2 Row element . . . . .  | 43 |
|            | 6.3 Cell element . . . . .   | 44 |
| Chapter 7  | Inline frames . . . . .  | 46 |
|            | 7.1 Inline element . . . . .                                       | 47 |
| Chapter 8  | Flow elements . . . . .  | 51 |
|            | 8.1 Flow element . . . . .   | 52 |
|            | 8.2 Footnote element . . . . .                                     | 53 |
| Chapter 9  | Style elements . . . . .   | 56 |
|            | 9.1 Preferences . . . . .  | 57 |
|            | 9.2 Colors . . . . .   | 57 |
|            | 9.3 Layer element . . . . .  | 58 |
|            | 9.4 Style elements . . . . .                                       | 58 |
| Chapter 10 | Special elements . . . . .   | 64 |
|            | 10.1 Variable element . . . . .                                    | 65 |

# Chapter 1

## Overview

This document describes the XML structure used by the Publishing Engine of the Adaptive Print Studio. The document contains:

- **Chapter 1 - Overview**
- **Chapter 2 - Introduction**
- **Chapter 3 - Document elements**
- **Chapter 4 - Page elementsPage elements**
- **Chapter 5 - Page elementsContent elements**
- **Chapter 6 - Page elementsTables**
- **Chapter 7 - Page elementsInline frames**
- **Chapter 8 - Page elementsFlow elements**
- **Chapter 9 - Page elementsStyle elements**
- **Chapter 10 - Page elementsSpecial elements**

## Chapter 2

### Introduction

This chapter introduces some basic principles when publishing InDesign documents using the Sitecore Publishing Engine.

## 2.1 Process overview

The following diagram explains the overall process.

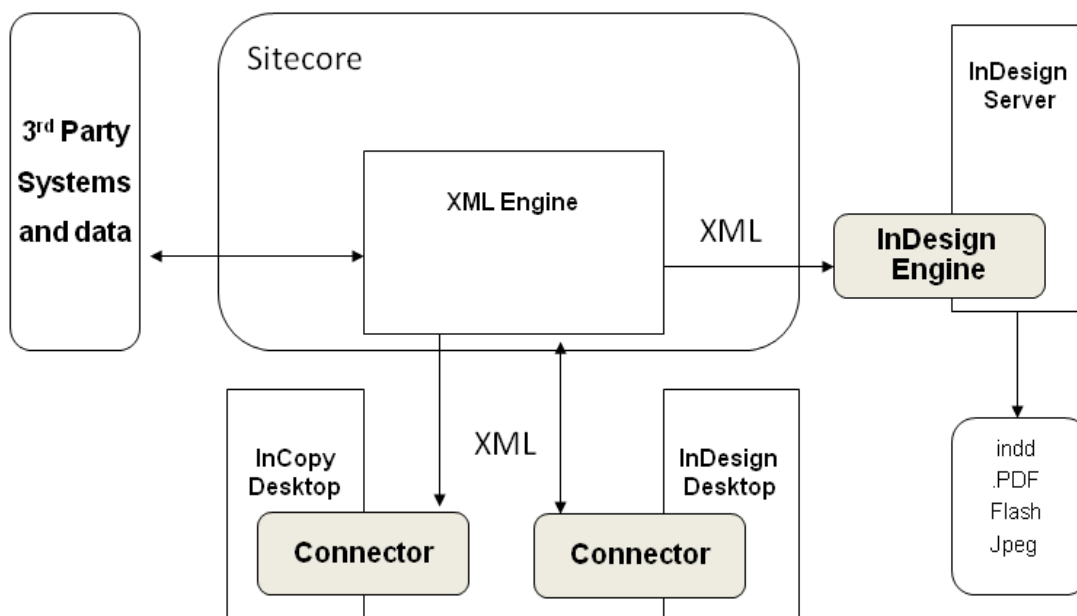

## 2.2 Sample documents

You can download a zip archive with samples that are used in this manual. This archive also contains the XML schema file that you can use building and validating XML snippets. The following schema

shows the overall structure.

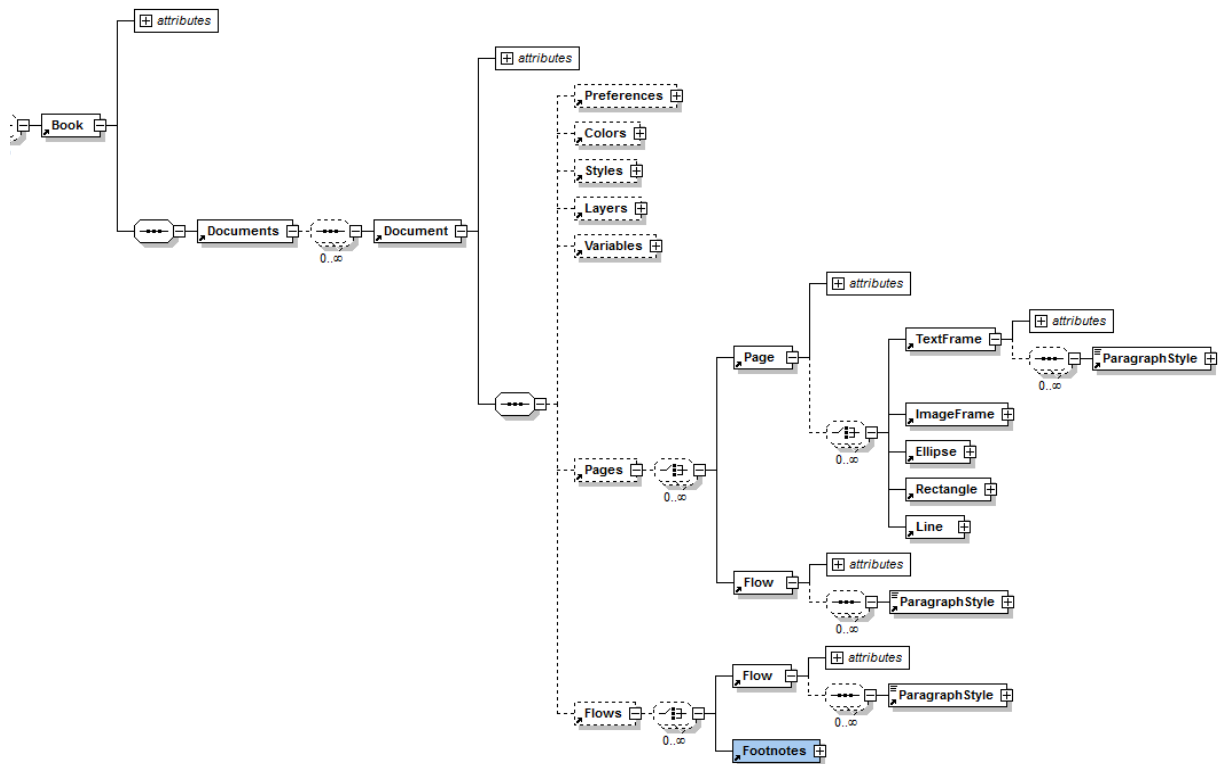

## Chapter 3

### Document elements

This chapter describes the elements that build the basic project and document structure.

### 3.1 Project element

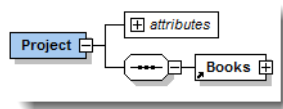

#### Project

| Attribute    | Def <sup>a</sup> | Value(s)      | Def. value | Explanation/examples  |
|--------------|------------------|---------------|------------|---|
| Units        | I                | mm<br>points  | points     | The units of measurement for the project (for font settings points are used always). Values points or mm, when no value is inserted or the attribute is not included the "points" value will be used. |
| CloseProject | I                | True<br>False | True       | Redundant   |

a.R=Required, I=Implied

### 3.2 Book element

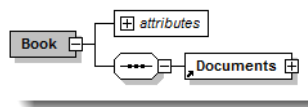

#### Book

| Attribute        | Def <sup>a</sup> | Value(s)                | Default Value | Explanation/examples  |
|------------------|------------------|-------------------------|---------------|---|
| CreateBook       | I                | True<br>False           | False         | True a book file is created.<br>False no book file is created.  |
| UseHighRes       | I                | True<br>False           | False         | False LowResSrc full dos path (c:\.\name.gif) is used for publishing.<br>True HighResSrc full dos path (c:\.\name.tiff) is used for publishing.     |
| AutoUpdate       | I                | True<br>False           | True          | Update the book file according to page order.   |
| BlankPage        | I                | True<br>False           | False         | Add blank InDesign page to document.  |
| BookFilename     | I                |                         |               | See note 1 at the end of this table.  |
| ConvertVars      | I                | True<br>False           | False         | False index variables are not converted to text.<br>True the variable will be converted.  |
| ExportPDF        | I                | True<br>False           | False         | Export the book file to PDF or not.<br>True a PDF file of the book is created   |
| ExportSWF        | I                | True<br>False           |               | Export to swf format when set to True   |
| name             | I                |                         |               | Name of item  |
| PageOrder        | I                | Odd<br>Even<br>Previous | Odd           | The page order start number:<br>Previous means start from previous document in book<br>Odd means start on odd page<br>Even means start on even page |
| PDFExportSetting | I                |                         |               | Value is the desired PDF export setting for books or documents.   |
| PDFFilename      | I                |                         |               | The full dos path (c:\.\name.pdf) of the InDesign book.   |
| PrintBook        | I                | True<br>False           | False         | Print the entire book.  |



**Book (Continued)**

| Attribute        | Def <sup>a</sup> | Value(s)  | Default Value | Explanation/examples  |
|------------------|------------------|---|---------------|---|
| PrintPreset      | I                |   |               | The printer settings to use when printing the book using "PrintBook".   |
| Repaginate       | I                |   |               | Only used internally by InDesign connector plug-in  |
| SitecoreID       | I                |   |               | The unique ID of the item   |
| SWFFilename      | I                |   |               | The filename to use for the SWF file.   |
| PageCurl         | I                | True<br>False   | True          | If True page curl is enabled.   |
| CurveQuality     | I                | 0 .. 100  | 80            | Sets the curve quality for the export.  |
| SpineGradient    | I                | True<br>False   | True          | If True, 'page spine' gradient is shown even when no page curl is in progress.  |
| ShowCornerTease  | I                | True<br>False   | True          | True a teaser animation is shown if user mouses over a corner.  |
| EdgePercentage   | I                | 0 .. 100  | 50            | Integer.<br>Real value indicating percentage of width/height for grabber area size.   |
| MediaHandling    | I                | IncludeAll<br>AppearanceOnly  | IncludeAll    | Sets the preferred method for handling dynamic media page items.  |
| FrameRate        | I                | 0 .. 100  | 24            | Integer<br>Set the frame rate for the generated SWF.  |
| GenerateHTML     | I                | True<br>False   | True          | Set to True, a HTML file generated as well.   |
| TranspBack       | I                | True<br>False   | False         | Has transparent background (when transparent background, page curl is not possible) when set to True.   |
| IncludePreloader | I                | True<br>False   | True          | Include preloader when set to True.   |
| JpegQuality      | I                | Minimum<br>Low<br>Medium<br>High<br>Maximum                                 | Medium        | Set the jpeg quality.   |
| Compression      | I                | Automatic<br>Lossless<br>JPEG   | Automatic     | Set the compression.  |
| Resolution       | I                | 0 .. ∞  | 72            | Integer.<br>Values in dpi<br>Sets the preferred raster resolution for the export.   |
| Spreads          | I                | True<br>False   | False         | Sets whether to export as reader's spreads.   |
| Threshold        | I                |   | 72            | Integer.<br>Values in dpi<br>Sets the raster resolution threshold.  |
| ResamplingType   | I                | None<br>Average<br>Subsample<br>Bicubic                                     | Average       | Sets the algorithm to be used for resampling raster images that exceed the specified resolution threshold.  |
| Sizing           | I                | Scale<br>Size<br>FitTo  | Scale         | Set the scale and fit settings to be applied for the export.<br>Scale set scaling percentage<br>Size set the exact width and height<br>FitTo fit to screen resolution |
| FitToValue       | I                | 1280 x 800<br>984 x 588<br>800 x 600<br>760 x 420<br>640 x 480<br>600 x 300 | 1280 x 800    | Set the value when Sizing is set to FitTo.<br>Values in ppi   |
| Height           | I                | 0 .. 100  | 100           | Real numbers<br>Set the height when Sizing is set to Size.  |

## Book (Continued)

| Attribute       | Def <sup>a</sup> | Value(s)                                 | Default Value | Explanation/examples   |
|-----------------|------------------|--|---------------|--|
| Width           | l                | 0 .. 100                                 | 100           | Real numbers<br>Set the width when Sizing is set to Size.  |
| TextExport      | l                | Vectorize<br>Live<br>Rasterize<br>Vellum | Vectorize     | Sets the text export policy for all text frame dictating how text is to be represented in the exported file. |
| Transparency    | l                | Ignore<br>Flatten<br>Native              | Ignore        | Sets the preferred method for handling transparency on a page or spread, if it exists.                       |
| UseNetwork      | l                | True<br>False                            | True          | Set whether to allow using network access in generated SWF.  |
| ViewAfterExport | l                | True<br>False                            | False         | Sets whether to view the generated SWF file after exporting.   |
| UpdateBook      | i                | True<br>False                            | True          | If set to true or left empty, will effect to book update.  |

a.R=Required, l=Implied

### Note 1:

If CreateBook=True, a book file is created. When CreateBook=True and ExportPDF=True, a PDF file of the book is created.

If CreateBook=True, there is never a PDF file or SWF file created of the document. If CreateBook = False and ExportPDF = True, there is a PDF of the (first) document created.

If CreateBook = False and ExportSWF = True, there is a flash of the (first) document created.

The different filenames (indb, PDF and SWF) are compiled based on the following logic:

If the specific attribute (BookFileName, PDFFileName and SWFFilename) has a value, that value is used for the filename.

If a value is left empty:

- The indb (book) filename = value of "OutputFolder" + value of "name" + value of "SitecoreID" + ".indb"
- The PDF filename = value of "OutputFolder" + value of "name" + value of "SitecoreID" + ".pdf"
- The SWF filename = value of "OutputFolder" + value of "name" + value of "SitecoreID" + ".pdf"

Outputfolder is derived from XML source file location.

If "name" is empty or attribute does not exist, the name is set to some default.

If "SitecoreID" is empty or attribute does not exist a unique ID is generated

### 3.3 Document element

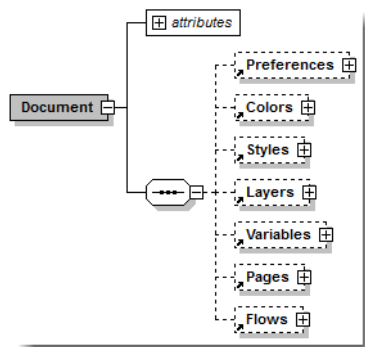

#### Document

| Attribute      | Def <sup>a</sup> | Value(s)          | Def. value        | Explanation/examples   |
|----------------|------------------|-------------------|-------------------|--|
| Name           | I                |                   |                   | The document filename (indd) is compiled based on the following logic:<br>If the DocFilename attribute has a value, that value is used for the filename.<br><br>If a value is left empty:<br>The indd filename = value of "OutputFolder" + value of "name" + value of "SitecoreID" + ".indb"<br><br>Outputfolder is derived from XML source file location.<br>If "name" is empty, the name is set to some default. |
| name           | I                |                   |                   | Name of the item.  |
| SitecoreID     | I                |                   |                   | The unique ID of the item.<br>If "SitecoreID" is empty a unique ID is generated.   |
| Type           | I                | Static<br>Dynamic | Dynamic           | The document type. Dynamic means document created from XML, Static means static InDesign document. When using Static the engine will use the document referred in the MasterFilename attribute and will save this document using the filename stated in the DocFilename attribute.   |
| PageWidth      | I                |                   |                   | The width of the pages specified in the amount of specified units of measurement.  |
| PageHeight     | I                |                   |                   | The height of the pages specified in the amount of specified units of measurement.   |
| Bleed          | I                |                   |                   | The amount of bleed.   |
| MasterFilename | R                |                   |                   | The full dos path (c:\.\name.indd) of the master document to use for this document. If left empty a new document is created using no master file.  |
| DocFilename    | R                |                   |                   | The full dos path (c:\.\name.indd) of the document to create/or use for this document. If left empty the filename is compiled using the name and SitecoreID attribute values. If those are left out or empty, the name is compiled using a unique identifier.  |
| InsertFile     | I                |                   |                   | Not supported using the Adaptive Print Studio.   |
| SaveAs         | I                |                   |                   | Not supported using the Adaptive Print Studio.   |
| PageCount      | I                |                   |                   | The page count is driven by inserted value (No value means as is in XML, Odd means document always ends on odd page, Even means document always ends on even page.   |
| ScriptFilename | I                |                   |                   | Full path of an InDesign script added to document. For additional information we refer to the Adobe website/SDKs.  |
| WaterMark      | I                |                   | False             | If set to True, a watermark is printed across all pages in the document.   |
| MarkText       | I                |                   | Default watermark | The watermark text.  |

## Document *(Continued)*

| Attribute     | Def <sup>a</sup> | Value(s)      | Def. value | Explanation/examples  |
|---------------|------------------|---------------|------------|---|
| MarkFontSize  | I                |               | 58         | The watermark text font size.   |
| MarkFontColor | I                |               | #555555    | The font color in rgb (#rrggbb).<br>For example #rrggbb (ff0000), which is red. |
| Shuffle       | I                | True<br>False | True       | If field is left empty, the master document settings are used.                  |

a.R=Required, I=Implied

## Chapter 4

### Page elements

This chapter describes the elements used to define pages and page objects.

## 4.1 Page element

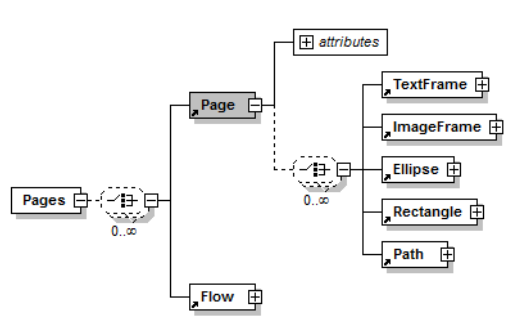

### Page

| Attribute    | Def <sup>a</sup> | Value(s)  | Def. value   | Explanation/examples   |
|--------------|------------------|---|--------------|--|
| name         | I                |   |              | Only used for internal purposes by InDesign connector.   |
| SitecoreID   | I                |   |              | Only used for internal purposes by InDesign connector.   |
| Number       | R                |   |              | The number used to identify the page. If a page exists, the page objects are added to that specific page. If it does not exist, a new page is created and the page objects are added to that new page. |
| MasterPrefix | R                |   |              | For InDesign for example "A", "B" and so on.   |
| MasterBase   | R                |   |              | For InDesign for example "Master".   |
| Transition   | I                | Blinds<br>Box<br>Comb<br>Cover<br>Dissolve<br>Fade<br>PageTurn<br>Push<br>Split<br>Uncover<br>Wipe<br>ZoomIn<br>ZoomOut   | None         | Sets the page transition.  |
| Direction    | I                | Down<br>Left<br>LeftDown<br>LeftUp<br>Right<br>RightDown<br>RightUp<br>Up<br>In<br>Out<br>Horizontal<br>Vertical<br>HorizontalIn HorizontalOut<br>VerticalIn<br>VerticalOut | None         | Sets the transition direction.   |
| Speed        | I                | Slow<br>Medium<br>Fast  | Default time | Sets the transition speed.   |
| ContNr       | I                | True<br>False   | True         | If the attribute is not specified, the value is taken from the master document.  |

a.R=Required, I=Implied

## 4.2 Textframe element

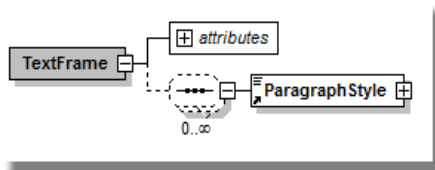

### TextFrame

| Attribute         | Def | Value(s)   | Def. value | Explanation/examples   |
|-------------------|-----|--|------------|--|
| Width             | R   |  |            | The width of the graphic frame in the specified units.   |
| Height            | R   |  |            | The height of the graphic frame in the specified units.  |
| X                 | R   |  |            | The horizontal position of the center point of the graphic frame with reference to the left corner point of the page in the specified units.   |
| Y                 | R   |  |            | The vertical position center point of the graphic frame with reference to the left corner point of the page in the specified units.  |
| Stroke            | I   |  |            | The stroke color in swatch or "#rrggbb" or cmyk "c=0;m=100;y=100;k=0;". Value of "None" mean no stroke. If a swatch is used and the swatch does not exist in the master document, it will be created using default color values. |
| StrokeThickness   | I   |  |            | The thickness of the stroke in points.   |
| StrokeType        | I   | Solid<br>ThickThick<br>ThickThin<br>ThickThinThick<br>ThinThick<br>ThinThickThin<br>ThinThin<br>Triple_Stroke<br>Canned Dashed 3x2<br>Canned Dashed 4x4<br>Left Slant Hash<br>Right Slant Hash<br>Straight Hash<br>Canned Dotted<br>Wavy<br>White Diamond<br>Japanese Dots  Dashed | Solid      | Stroke values  |
| Z-index           | R   |  |            | The z-index of the graphic frame. Can be used to move a frame to the front/back. If the z-index is unknown, use any value like for example 0.  |
| Background        | I   |  |            | Background color in swatch or "#rrggbb" or cmyk "c=0;m=100;y=100;k=0;". Value of "None" mean no stroke. If a swatch is used and the swatch does not exist in the master document, it will be created using default color values. |
| LayerName         | R   |  |            | The name of the layer where the graphic frame is put on. If the layer does not exist, it is created using defaults.  |
| Rotation          | I   |  |            | The rotation of the graphic frame rotated round the centre middle. In degrees.   |
| VerticalAlignment | I   | Top<br>Middle<br>Bottom<br>Justify   | Top        | The vertical alignment of the content in the text frame.   |
| Opacity           | I   |  |            | The opacity in percentage (values from 0 to 100) of the frame. When value is set on "0" no fill color is shown (means 0%) When the attribute is not used the standard InDesign value is used.                                    |
| Transparency      | I   |  |            | The transparency of the graphic frame (as in InDesign). When value is set on "0" no fill color is shown (means 0%) When the attribute is not used the standard InDesign value is used.   |

## TextFrame

| Attribute         | Def | Value(s)  | Def. value | Explanation/examples   |
|-------------------|-----|---|------------|--|
| Name              | l   |   |            | Only used internally by the InDesign connector.  |
| CornerRadius      | l   |   |            | The corner effects setting in the specified units of the graphic frame.  |
| CornerType        | l   | None<br>Rounded<br>Inverse Rounded<br>Inset<br>Bevel<br>Fancy |            | The corner effect setting of the graphic frame.<br>Ex: None None None None   |
| margin-left       | l   |   |            | Left margin in the specified units.  |
| margin-top        | l   |   |            | Top margin in the specified units.   |
| margin-right      | l   |   |            | Right margin in the specified units.   |
| margin-bottom     | l   |   |            | Bottom margin in the specified units.  |
| Id                | l   |   |            | Only used internally.  |
| Identifier        | l   |   |            | Only used internally.  |
| FlowName          | l   |   |            | Name of the flow used for threaded text frames.  |
| FlowOrder         | l   |   |            | The order of the text frame in the entire flow.  |
| SitecoreID        | l   |   |            | Only used internally.  |
| SitecoreFieldname | l   |   |            | Only used internally.  |
| HorizontalScale   | l   |   |            | Value - / +. Value of 0.8 means scale to 80%. Value of 2 means 200%. HorizontalScale and VerticalScale always need to be set both in order to use scaling.   |
| VerticalScale     | l   |   |            | Value - / +. Value of 0.8 means scale to 80%. Value of 2 means 200%. HorizontalScale and VerticalScale always need to be set both in order to use scaling.   |
| Skew              | l   | 0-360   |            | Value in degrees.  |
| NrOfColumns       | l   |   |            | Value number of columns used for text frames.  |
| ColumnGutter      | l   |   |            | Value of gutter between columns.   |
| ObjectStyle       | l   |   |            | An InDesign Object Style can be used for formatting (effects). If the name of the Object Style used in the master is used as value of this attribute it will be applied. If the objectstyle does not exist, it is NOT created automatically. |
| ScriptOverflow    | l   |   |            | The full file(s) path. Script is executed when text overflow is encountered for the text frame.<br>3 parameters are sent to the script.<br>par1 documentname<br>par2 XML iD<br>par3 InDesign GUID  |
| RunOnce           | l   | True<br>False   | True       | True the scriptoverflow is only run once.<br>False the script is executed until no overflow is encountered.  |
| RunScript         | l   |   |            | The full file(s) path. Three parameters are sent to the script.<br>par1 documentname<br>par2 XML iD<br>par3 InDesign GUID  |
| FitFrame          | l   | True<br>False   | False      | True the frame is auto fitted according to the text in the frame.  |
| ShowOverflow      | l   | True<br>False   | False      | Show overflow indicator. Overflow frame uses "OverFlow" objectstyle and content uses "OverFlow" paragraphstyle. The calling frame gets a strokecolor called "OverFlow" Only works in InDesign server.  |
| FillTint          | l   |   |            | The percentage of the tint for the background color.   |
| StrokeTint        | l   |   |            | The percentage of the tint for the stroke color.   |



## TextFrame

| Attribute | Def | Value(s)  | Def. value | Explanation/examples  |
|-----------|-----|---|------------|---|
| WMode     | I   | 0<br>1<br>2<br>3<br>4<br>5<br>6<br>7<br>8   |            | Wrap mode<br><br>0 no text wrap<br>1 jump object<br>2 jump to next column<br>3 wrap around bounding box<br>4 Invalid, unimplemented<br>5 Invalid, unimplemented<br>6 wrap around object shape<br>7 Invalid, unimplemented<br>8 Invalid, unimplemented |
| WOffset   | I   | top;left;bottom;right;single  |            | Wrap offset<br>Distance 1;2;1;2;0<br>Whether the item only supports one value for all sides (that is topMargin is the only valid margin) values 1/0   |
| WInvert   | I   | 0/1   |            | Invert text wrap  |
| WSide     | I   | 0<br>1<br>2<br>3<br>4<br>5  |            | Wrap side<br><br>0 Both left & right sides<br>1 Left side<br>2 Right side<br>3 Side Towards Spine<br>4 Side Away from Spine<br>5 Largest Area   |
| WIgnore   | I   | 1<br>0  |            | Ignore textwrap (only for textframes)<br><br>1 Ignore textwrap  |
| LCap      | I   | 0<br>1<br>2   |            | Line cap<br><br>0 But cap<br>1 Round cap<br>2 Projecting cap  |
| JType     | I   | 0<br>1<br>2   |            | Join type<br><br>0 Miter join<br>1 Round join<br>2 Bevel join   |
| MLim      | I   |   |            | Miter limit   |
| SAlign    | I   | 0<br>1<br>2   |            | Stroke alignment<br><br>0 Align stroke to center<br>1 Align stroke to inside<br>2 Align stroke to outside   |
| LEnd      | I   | Simple<br>Bar<br>SquareSolid<br>Square<br>CircleSolid<br>Circle<br>Curved<br>Barbed<br>TriangleWide<br>Triangle<br>SimpleWide |            | (Line end) and LStart (line start)  |
| BalCols   | I   | True/False  |            | Balance columns   |

## 4.3 ImageFrame element

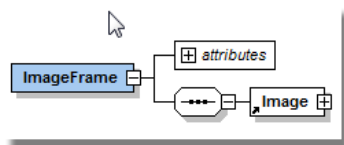

### ImageFrame

| Attribute         | Def <sup>a</sup> | Value(s)   | Def. value | Explanation/examples  |
|-------------------|------------------|--|------------|---|
| Width             | R                |  |            | The width of the graphic frame in the specified units.  |
| Height            | R                |  |            | The height of the graphic frame in the specified units.   |
| X                 | R                |  |            | The horizontal position of the center point of the graphic frame with reference to the left corner point of the page in the specified units.  |
| Y                 | R                |  |            | The vertical position center point of the graphic frame with reference to the left corner point of the page in the specified units.   |
| Stroke            | I                |  |            | The stroke color in swatch or "#rrggbb" or CMYK: "c=0;m=100;y=100;k=0;". Value of "None" mean no stroke. If a swatch is used and the swatch does not exist in the master document, it will be created using default color values. |
| StrokeThickness   | I                |  |            | The thickness of the stroke in points.  |
| StrokeType        | I                | Solid<br>ThickThick<br>ThickThin<br>ThickThinThick<br>ThinThick<br>ThinThickThin<br>ThinThin<br>Triple_Stroke<br>Canned Dashed 3x2<br>Canned Dashed 4x4<br>Left Slant Hash<br>Right Slant Hash<br>Straight Hash<br>Canned Dotted<br>Wavy<br>White Diamond<br>Japanese Dots  Dashed | Solid      | Stroke values.  |
| Z-Index           | R                |  |            | The z-index of the graphic frame. Can be used to move a frame to the front/back. If the z-index is unknown, use any value like for example 0.   |
| Background        | I                |  |            | Background color in swatch or "#rrggbb" or cmyk "c=0;m=100;y=100;k=0;". Value of "None" mean no stroke. If a swatch is used and the swatch does not exist in the master document, it will be created using default color values.  |
| LayerName         | R                |  |            | The name of the layer where the graphic frame is put on. If the layer does not exist, it is created using defaults.   |
| Rotation          | I                |  |            | The rotation of the graphic frame rotated round the centre middle. In degrees.  |
| VerticalAlignment | I                | Top<br>Middle<br>Bottom<br>Justify   | Top        | The vertical alignment of the content in the text frame.  |
| Opacity           | I                |  |            | The opacity in percentage (values from 0 to 100) of the graphic frame.  |
| Transparency      | I                |  |            | The transparency of the graphic frame (as in Indesign).   |
| Name              | I                |  |            | Frame label (not used for now).   |
| CornerRadius      | I                |  |            | The corner effects setting in the specified units of the graphic frame.   |

## ImageFrame (Continued)

| Attribute         | Def <sup>a</sup> | Value(s)   | Def. value | Explanation/examples   |
|-------------------|------------------|--|------------|--|
| CornerType        | I                | None<br>Rounded<br>Inverse Rounded<br>Inset<br>Bevel<br>Fancy  |            | The corner effect setting of the graphic frame.<br>Ex: None None None None   |
| Margin-left       | I                |  |            | Left margin in the specified units.  |
| Margin-top        | I                |  |            | Top margin in the specified units.   |
| Margin-right      | I                |  |            | Right margin in the specified units.   |
| Margin-bottom     | I                |  |            | Bottom margin in the specified units.  |
| Id                | I                |  |            | Only used internally.  |
| Identifier        | I                |  |            | Only used internally.  |
| SitecoreID        | I                |  |            | Only used internally.  |
| SitecoreFieldname | I                |  |            | Only used internally.  |
| Scaling           | I                | None<br>AsIs<br>Fit Content to Frame<br>Fit Frame to Content<br>Center Content<br>Fit Content Proportionally<br>Fill Frame Proportionally<br>Fill Frame Proportionally and Center<br>Fit Content Proportionally and Center |            | Images can be scaled automatically by using the values of this attribute.<br><br>None use image width, height, x and y to position the image.<br>AsIs place the image in its actual with and height.   |
| HorizontalScale   | I                |  |            | Value - / +. Value of 0.8 means scale to 80%. Value of 2 means 200%. HorizontalScale and VerticalScale always need to be set both in order to use scaling.   |
| VerticalScale     | I                |  |            | Value - / +. Value of 0.8 means scale to 80%. Value of 2 means 200%. HorizontalScale and VerticalScale always need to be set both in order to use scaling.   |
| Skew              | I                |  |            | Value in degrees.  |
| Center            | I                | True<br>False  | False      | False do nothing<br>True the image is placed as Indesign value "Center Content", attribute is used with scaling attributes.  |
| FitFrame          | I                | True<br>False  | False      | False do nothing<br>True the frame is placed as Indesign value "Fit frame to Content", attribute is used with scaling attributes (values).   |
| ObjectStyle       | I                |  |            | An InDesign Object Style can be used for formatting (effects). When the name of the Object Style used in the master is used as value of this attribute it will be applied. If the objectstyle does not exist, it is NOT created automatically.     |
| RunScript         | I                |  |            | The full file(s) path. 3 Parameters are sent to the script.<br>par1 documentname<br>par2 XML iD<br>par3 InDesign GUID  |
| FillTint          | I                |  |            | The percentage of the tint for the background color.   |
| StrokeTint        | I                |  |            | The percentage of the tint for the stroke color.   |
| WMode             | I                | 0<br>1<br>2<br>3<br>4<br>5<br>6<br>7<br>8  |            | Wrap mode.<br>0 no text wrap<br>1 jump object<br>2 jump to next column<br>3 wrap around bounding box<br>4 Invalid, unimplemented<br>5 Invalid, unimplemented<br>6 wrap around object shape<br>7 Invalid, unimplemented<br>8 Invalid, unimplemented |

### ImageFrame (Continued)

| Attribute | Def <sup>a</sup> | Value(s)  | Def. value | Explanation/examples  |
|-----------|------------------|---|------------|---|
| WOffset   | I                | top;left;bottom;right;single  |            | Distance of wrap offset<br>Ex: 1;2;1;2;0;<br><br>Whether the item only supports one value for all sides (that is topMargin is the only valid margin) values 1/0 |
| WInvert   | I                | 0/1   |            | Invert text wrap  |
| WSide     | I                | 0<br>1<br>2<br>3<br>4<br>5  |            | Wrap side<br><br>0 both left & right sides<br>1 Left side<br>2 Right side<br>3 Side Towards Spine<br>4 Side Away from Spine<br>5 Largest Area                   |
| LCap      | I                | 0<br>1<br>2   |            | Line cap<br><br>0 But cap<br>1 Round cap<br>2 Projecting cap  |
| JType     | I                | 0<br>1<br>2   |            | Join type<br><br>0 Miter join<br>1 Round join<br>2 Bevel join   |
| MLim      | I                |   |            | Miter limit   |
| SAlign    | I                | 0<br>1<br>2   |            | Stroke alignment)<br><br>0 Align stroke to center<br>1 Align stroke to inside<br>2 Align stroke to outside  |
| LEnd      | I                | Simple<br>Bar<br>SquareSolid<br>Square<br>CircleSolid<br>Circle<br>Curved<br>Barbed<br>TriangleWide<br>Triangle<br>SimpleWide |            | (Line end) and LStart (line start).   |

a.R=Required, I=Implied

## 4.4 Image element

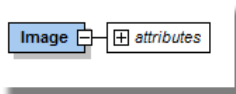

### Image

| Attribute | Def <sup>a</sup> | Value(s) | Def. value | Explanation/examples  |
|-----------|------------------|----------|------------|---|
| Width     | R                |          |            | The width of the graphic frame in the specified units.  |
| Height    | R                |          |            | The height of the graphic frame in the specified units.   |
| X         | R                |          |            | The horizontal position of the center point of the graphic frame with reference to the center point of the ImageFrame in the specified units. |
| Y         | R                |          |            | The vertical position center point of the graphic frame with reference to the center point of the ImageFrame in the specified units.          |

**Image (Continued)**

| Attribute         | Def <sup>a</sup> | Value(s)                                  | Def. value | Explanation/examples   |
|-------------------|------------------|---|------------|--|
| LowResSrc         | R                |   |            | The full dos path (c:\.\name.gif) of low resolution images.  |
| HighResSrc        | R                |   |            | The full dos path (c:\.\name.tiff) of high resolution images.  |
| Name              | I                |   |            | Only used internally.  |
| Rotation          | I                |   |            | The rotation of the graphic frame rotated round the centre middle. In degrees.   |
| Id                | I                |   |            | Only used internally.  |
| Identifier        | I                |   |            | Only used internally.  |
| SitecoreID        | I                |   |            | Only used internally.  |
| SitecoreFieldname | I                |   |            | Only used internally.  |
| HorizontalScale   | I                |   |            | Value - / +. Value of 0.8 means scale to 80%. Value of 2 means 200%. HorizontalScale and VerticalScale always need to be set both in order to use scaling.   |
| VerticalScale     | I                |   |            | Value - / +. Value of 0.8 means scale to 80%. Value of 2 means 200%. HorizontalScale and VerticalScale always need to be set both in order to use scaling.   |
| Skew              | I                |   |            | Value in degrees.  |
| ObjectStyle       | I                |   |            | An InDesign Object Style can be used for formatting (effects). When the name of the Object Style used in the master is used as value of this attribute it will be applied. If the objectstyle does not exist, it is NOT created automatically.     |
| RunScript         | I                |   |            | The full file(s) path. 3 parameters are sent to the script.<br>par1 document name<br>par2 XML iD<br>par3 InDesign GUID   |
| Wmode             | I                | 0<br>1<br>2<br>3<br>4<br>5<br>6<br>7<br>8 |            | Wrap mode.<br>0 No text wrap<br>1 Jump object<br>2 Jump to next column<br>3 Wrap around bounding box<br>4 Invalid, unimplemented<br>5 Invalid, unimplemented<br>6 Wrap around object shape<br>7 Invalid, unimplemented<br>8 Invalid, unimplemented |
| WOffset           | I                | top;left;bottom:right;single              |            | Distance of wrap offset<br>Ex: 1;2;1;2;0;<br><br>Whether the item only supports one value for all sides (that is topMargin is the only valid margin) values 1/0  |
| WInvert           | I                | 0/1                                       |            | Invert text wrap   |
| WSide             | I                | 0<br>1<br>2<br>3<br>4<br>5                |            | Wrap side<br>0 Both left & right sides<br>1 Left side<br>2 Right side<br>3 Side Towards Spine<br>4 Side Away from Spine<br>5 Largest Area  |
| WCont             | I                | 0<br>1<br>2<br>3<br>4<br>5                | 0          | Wrap contour<br>0 Graphic Bounds<br>1 Detect Edges<br>2 Using Alpha Channel<br>3 Using Photoshop Path<br>4 Graphic Frame<br>5 SameAsClip   |

a.R=Required, I=Implied

## 4.5 Ellipse element



### Ellipse

| Attribute       | Def <sup>a</sup> | Value(s)   | Def. value | Explanation/examples   |
|-----------------|------------------|--|------------|--|
| Width           | R                |  |            | The width of the graphic frame in the specified units.   |
| Height          | R                |  |            | The height of the graphic frame in the specified units.  |
| X               | R                |  |            | The horizontal position of the center point of the graphic frame with reference to the left corner point of the page in the specified units.   |
| Y               | R                |  |            | The vertical position center point of the graphic frame with reference to the left corner point of the page in the specified units.  |
| Stroke          | I                |  |            | The stroke color in swatch or "#rrggbb" or cmyk "c=0;m=100;y=100;k=0;". Value of "None" mean no stroke. If a swatch is used and the swatch does not exist in the master document, it will be created using default color values. |
| StrokeThickness | I                |  |            | The thickness of the stroke in points.   |
| StrokeType      | I                | Solid<br>ThickThick<br>ThickThin<br>ThickThinThick<br>ThinThick<br>ThinThickThin<br>ThinThin<br>Triple_Stroke<br>Canned Dashed 3x2<br>Canned Dashed 4x4<br>Left Slant Hash<br>Right Slant Hash<br>Straight Hash<br>Canned Dotted<br>Wavy<br>White Diamond<br>Japanese Dots  Dashed | Solid      | Stroke values  |
| Z-Index         | R                |  |            | The z-index of the graphic frame. Can be used to move a frame to the front/back. If the z-index is unknown, use any value like for example 0.  |
| Background      | I                |  |            | Background color in swatch or "#rrggbb" or cmyk "c=0;m=100;y=100;k=0;". Value of "None" mean no stroke. If a swatch is used and the swatch does not exist in the master document, it will be created using default color values. |
| LayerName       | R                |  |            | The name of the layer where the graphic frame is put on. If the layer does not exist, it is created using defaults.  |
| Rotation        | I                |  |            | The rotation of the graphic frame rotated round the centre middle. In degrees.   |
| Opacity         | I                |  |            | The opacity in percentage (values from 0 to 100) of the graphic frame.   |
| Transparency    | I                |  |            | The transparency of the graphic frame (as in Indesign).  |
| Name            | I                |  |            | Only used internally.  |
| CornerRadius    | I                |  |            | The corner effects setting in the specified units of the graphic frame.  |
| CornerType      | I                | None<br>Rounded<br>Inverse Rounded<br>Inset<br>Bevel<br>Fancy  |            | The corner effect setting of the graphic frame (as in Indesign).<br>Ex: None None None None  |
| Id              | I                |  |            | Only used internally.  |

## Ellipse (Continued)

| Attribute         | Def <sup>a</sup> | Value(s)                                  | Def. value | Explanation/examples  |
|-------------------|------------------|---|------------|---|
| Identifier        | I                |   |            | Only used internally.   |
| SitecoreID        | I                |   |            | Only used internally.   |
| SitecoreFieldname | I                |   |            | Only used internally.   |
| HorizontalScale   | I                |   |            | Value - / +. Value of 0.8 means scale to 80%. Value of 2 means 200%. HorizontalScale and VerticalScale always need to be set both in order to use scaling.  |
| VerticalScale     | I                |   |            | Value - / +. Value of 0.8 means scale to 80%. Value of 2 means 200%. HorizontalScale and VerticalScale always need to be set both in order to use scaling.  |
| Skew              | I                |   |            | Value in degrees.   |
| ObjectStyle       | I                |   |            | An InDesign Object Style can be used for formatting (effects). When the name of the Object Style used in the master is used as value of this attribute it will be applied. If the objectstyle does not exist, it is NOT created automatically.    |
| RunScript         | I                |   |            | The full file(s) path. 3 parameters are sent to the script.<br>par1 documentname<br>par2 XML iD<br>par3 InDesign GUID   |
| FillTint          | I                |   |            | The percentage of the tint for the background color   |
| StrokeTint        | I                |   |            | The percentage of the tint for the stroke color.  |
| WMode             | I                | 0<br>1<br>2<br>3<br>4<br>5<br>6<br>7<br>8 |            | Wrap mode<br>0 no text wrap<br>1 jump object<br>2 jump to next column<br>3 wrap around bounding box<br>4 Invalid, unimplemented<br>5 Invalid, unimplemented<br>6 wrap around object shape<br>7 Invalid, unimplemented<br>8 Invalid, unimplemented |
| WOffset           | I                | top;left;bottom;right;single              |            | Distance of wrap offset<br>Ex: 1;2;1;2;0<br><br>Whether the item only supports one value for all sides (that is topMargin is the only valid margin) values 1/0.   |
| WInvert           | I                | 0/1                                       |            | Invert text wrap.   |
| WSide             | I                | 0<br>1<br>2<br>3<br>4<br>5                |            | Wrap side<br>0 both left & right sides<br>1 Left side<br>2 Right side<br>3 Side Towards Spine<br>4 Side Away from Spine<br>5 Largest Area   |
| LCap              | I                | 0<br>1<br>2                               |            | Line cap<br>0 But cap<br>1 Round cap<br>2 Projecting cap  |
| JType             | I                | 0<br>1<br>2                               |            | Join type<br>0 Miter join<br>1 Round join<br>2 Bevel join   |
| MLim              | I                |   |            | Miter limit   |

## Ellipse (Continued)

| Attribute      | Def <sup>a</sup> | Value(s)  | Def. value | Explanation/examples  |
|----------------|------------------|---|------------|---|
| SAlign         | I                | 0<br>1<br>2   |            | Stroke alignment<br>0 Align stroke to center<br>1 Align stroke to inside<br>2 Align stroke to outside |
| LEnd<br>LStart | I                | Simple<br>Bar<br>SquareSolid<br>Square<br>CircleSolid<br>Circle<br>Curved<br>Barbed<br>TriangleWide<br>Triangle<br>SimpleWide |            | Line end<br>Line start  |

a.R=Required, I=Implied



## 4.6 Rectangle element

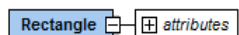

### Rectangle

| Attribute       | Def <sup>a</sup> | Value(s)   | Def. value | Explanation/examples   |
|-----------------|------------------|--|------------|--|
| Width           | R                |  |            | The width of the graphic frame in the specified units.   |
| Height          | R                |  |            | The height of the graphic frame in the specified units.  |
| X               | R                |  |            | The horizontal position of the center point of the graphic frame with reference to the left corner point of the page in the specified units.   |
| Y               | R                |  |            | The vertical position center point of the graphic frame with reference to the left corner point of the page in the specified units.  |
| Stroke          | I                |  |            | The stroke color in swatch or "#rrggbb" or cmyk "c=0;m=100;y=100;k=0;". Value of "None" mean no stroke. If a swatch is used and the swatch does not exist in the master document, it will be created using default color values. |
| StrokeThickness | I                |  |            | The thickness of the stroke in points.   |
| StrokeType      | I                | Solid<br>ThickThick<br>ThickThin<br>ThickThinThick<br>ThinThick<br>ThinThickThin<br>ThinThin<br>Triple_Stroke<br>Canned Dashed 3x2<br>Canned Dashed 4x4<br>Left Slant Hash<br>Right Slant Hash<br>Straight Hash<br>Canned Dotted<br>Wavy<br>White Diamond<br>Japanese Dots  Dashed | Solid      | Stroke values  |
| Z-Index         | R                |  |            | The z-index of the graphic frame. Can be used to move a frame to the front/back. If the z-index is unknown, use any value like for example 0.  |
| Background      | I                |  |            | Background color in swatch or "#rrggbb" or cmyk "c=0;m=100;y=100;k=0;". Value of "None" mean no stroke. If a swatch is used and the swatch does not exist in the master document, it will be created using default color values. |
| LayerName       | R                |  |            | The name of the layer where the graphic frame is put on. If the layer does not exist, it is created using defaults   |
| Rotation        | I                |  |            | The rotation of the graphic frame rotated round the centre middle. In degrees.   |
| Opacity         | I                |  |            | The opacity in percentage (values from 0 to 100) of the graphic frame.   |
| Transparency    | I                |  |            | The transparency of the graphic frame (as in Indesign).  |
| Name            | I                |  |            | Only used internally.  |
| CornerRadius    | I                |  |            | The corner effects setting in the specified units of the graphic frame.  |
| CornerType      | I                | None<br>Rounded<br>Inverse Rounded<br>Inset<br>Bevel<br>Fancy  |            | The corner effect setting of the graphic frame (as in Indesign).<br>Ex: None None None None  |
| Id              | I                |  |            | Only used internally.  |

## Rectangle (Continued)

| Attribute         | Def <sup>a</sup> | Value(s)                                  | Def. value | Explanation/examples  |
|-------------------|------------------|---|------------|---|
| Identifier        | I                |   |            | Only used internally.   |
| SitecoreID        | I                |   |            | Only used internally.   |
| SitecoreFieldname | I                |   |            | Only used internally.   |
| HorizontalScale   | I                |   |            | Value - / +. Value of 0.8 means scale to 80%. Value of 2 means 200%. HorizontalScale and VerticalScale always need to be set both in order to use scaling.  |
| VerticalScale     | I                |   |            | Value - / +. Value of 0.8 means scale to 80%. Value of 2 means 200%. HorizontalScale and VerticalScale always need to be set both in order to use scaling.  |
| Skew              | I                |   |            | Value in degrees.   |
| ObjectStyle       | I                |   |            | An InDesign Object Style can be used for formatting (effects). When the name of the Object Style used in the master is used as value of this attribute it will be applied. If the objectstyle does not exist, it is NOT created automatically.    |
| RunScript         | I                |   |            | The full file(s) path. 3 parameters are sent to the script.<br>par1 documentname<br>par2 XML iD<br>par3 InDesign GUID   |
| FillTint          | I                |   |            | The percentage of the tint for the background color.  |
| StrokeTint        | I                |   |            | The percentage of the tint for the stroke color.  |
| WMode             | I                | 0<br>1<br>2<br>3<br>4<br>5<br>6<br>7<br>8 |            | Wrap mode<br>0 no text wrap<br>1 jump object<br>2 jump to next column<br>3 wrap around bounding box<br>4 Invalid, unimplemented<br>5 Invalid, unimplemented<br>6 wrap around object shape<br>7 Invalid, unimplemented<br>8 Invalid, unimplemented |
| WOffset           | I                | top;left;bottom:right;single              |            | Distance of wrap offset<br>Ex: 1;2;1;2;0;<br>Whether the item only supports one value for all sides (that is topMargin is the only valid margin) values 1/0   |
| WInvert           | I                | 0/1                                       |            | Invert text wrap.   |
| WSide             | I                | 0<br>1<br>2<br>3<br>4<br>5                |            | Wrap side<br>0 both left & right sides<br>1 Left side<br>2 Right side<br>3 Side Towards Spine<br>4 Side Away from Spine<br>5 Largest Area   |
| LCap              | I                | 0<br>1<br>2                               |            | Line cap<br>0 But cap<br>1 Round cap<br>2 Projecting cap  |
| JType             | I                | 0<br>1<br>2                               |            | Join type<br>0 Miter join<br>1 Round join<br>2 Bevel join   |
| MLim              | I                |   |            | Miter limit   |

## Rectangle (Continued)

| Attribute | Def <sup>a</sup> | Value(s)  | Def. value | Explanation/examples  |
|-----------|------------------|---|------------|---|
| SAlign    | I                | 0<br>1<br>2   |            | Stroke alignment<br>0 Align stroke to center<br>1 Align stroke to inside<br>2 Align stroke to outside |
| LEnd      | I                | Simple<br>Bar<br>SquareSolid<br>Square<br>CircleSolid<br>Circle<br>Curved<br>Barbed<br>TriangleWide<br>Triangle<br>SimpleWide |            | (Line end) and LStart (line start)  |

a.R=Required, I=Implied

## 4.7 Line element

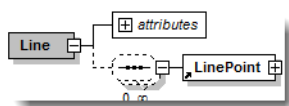

### Line

| Attribute    | Def <sup>a</sup> | Value(s)  | Default Value | Explanation/examples  |
|--------------|------------------|---|---------------|---|
| Width        | I                |   |               | The width of the graphic frame in the specified units. Be aware that initially the line is determined by the LinePoints. The width and height is only used to scale the object once created. When publishing a straight (horizontal) line, the width is not used.               |
| Height       | I                |   |               | The width of the graphic frame in the specified units. Be aware that initially the line is determined by the LinePoints. The width and height is only used to scale the object once created. When publishing a straight (horizontal) line, the width is not used.               |
| X            | I                |   |               | The horizontal position of the center point of the graphic frame with reference to the left corner point of the page in the specified units. Be aware that the line is initially determined by the LinePoints. The X and Y are only used to move the object once it is created. |
| Y            | I                |   |               | The vertical position center point of the graphic frame with reference to the left corner point of the page in the specified units. Be aware that the line is initially determined by the LinePoints. The X and Y are only used to move the object once it is created.          |
| Background   | I                |   |               | Background color in swatch or "#rrggbb" or cmyk "c=0;m=100;y=100;k=0;". Value of "None" mean no stroke. If a swatch is used and the swatch does not exist in the master document, it will be created using default color values.  |
| Closed       | I                | True<br>False   |               | True start and end point are joined.<br>False no joining.   |
| CornerRadius | I                | N/A   |               | Frame label (not used for now).   |
| CornerType   | I                | None<br>Rounded<br>Inverse Rounded<br>Inset<br>Bevel<br>Fancy |               | The corner effects setting in the specified units of the graphic frame. Ex: None None None None   |
| FillTint     | I                |   |               | The percentage of the tint for the background color.  |
| Id           | I                |   |               | Only used internally.   |

**Line (Continued)**

| Attribute         | Def <sup>a</sup> | Value(s)  | Default Value | Explanation/examples   |
|-------------------|------------------|---|---------------|--|
| Identifier        | I                |   |               | Only used internally.  |
| JType             | I                | 0<br>1<br>2   |               | Join type<br>0 Miter join<br>1 Round join<br>2 Bevel join  |
| LayerName         | I                |   |               | The name of the layer where the graphic frame is put on. If the layer does not exist, it is created using defaults.  |
| LCap              | I                | 0<br>1<br>2   |               | Line cap<br>0 But cap<br>1 Round cap<br>2 Projecting cap   |
| LEnd<br>LStart    | I                | Simple<br>Bar<br>SquareSolid<br>Square<br>CircleSolid<br>Circle<br>Curved<br>Barbed<br>TriangleWide<br>Triangle<br>SimpleWide |               | (Line end) and LStart (line start)   |
| MLim              | I                |   |               | Miter limit  |
| Name              | I                |   |               | Only used internally.  |
| ObjectStyle       | I                |   |               | An InDesign Object Style can be used for formatting (effects). When the name of the Object Style used in the master is used as value of this attribute it will be applied. If the objectstyle does not exist, it is NOT created automatically. |
| Opacity           | I                |   |               | The vertical alignment of the content in the textframe.  |
| Rotation          | I                |   |               | The rotation of the graphic frame rotated round the centre middle. In degrees.   |
| RunScript         | I                |   |               | The full file(s) path. Three parameters are sent to the script.<br>par1 documentname<br>par2 XML iD<br>par3 InDesign GUID  |
| SAlign            | I                | 0<br>1<br>2   |               | Stroke alignment<br>0 Align stroke to center<br>1 Align stroke to inside<br>2 Align stroke to outside  |
| SitecoreFieldname | I                |   |               | Only used internally.  |
| SitecoreID        | I                |   |               | Only used internally.  |
| Stroke            | I                |   |               | The stroke color in swatch or "#rrggbb" or cmyk "c=0;m=100;y=100;k=0;". Value of "None" mean no stroke. If a swatch is used and the swatch does not exist in the master document, it will be created using default color values.               |
| StrokeThickness   | I                |   |               | The thickness of the stroke in points.   |
| StrokeTint        | I                |   |               | The percentage of the tint for the stroke color.   |

### Line (Continued)

| Attribute    | Def <sup>a</sup> | Value(s)   | Default Value | Explanation/examples   |
|--------------|------------------|--|---------------|--|
| StrokeType   | I                | Solid<br>ThickThick<br>ThickThin<br>ThickThinThick<br>ThinThick<br>ThinThickThin<br>ThinThin<br>Triple_Stroke<br>Canned Dashed 3x2<br>Canned Dashed 4x4<br>Left Slant Hash<br>Right Slant Hash<br>Straight Hash<br>Canned Dotted<br>Wavy<br>White Diamond<br>Japanese Dots  Dashed | Solid         | Stroke values  |
| Transparency | I                | 0-100  |               | Real Numbers<br>The opacity in percentage of the graphic frame.  |
| WInvert      | I                | 0<br>1   |               | Invert text wrap   |
| WMode        | I                | 0<br>1<br>2<br>3<br>4<br>5<br>6<br>7<br>8  |               | 0 (no text wrap)<br>1 (jump object)<br>2 (jump to next column)<br>3 (wrap around bounding box)<br>4 Invalid, unimplemented<br>5 Invalid, unimplemented<br>6 (wrap around object shape)<br>7 Invalid, unimplemented<br>8 Invalid, unimplemented |
| WOffset      | I                | top<br>left<br>bottom<br>right<br>single   |               | Distance of wrap offset<br>Ex: 1;2;1;2;0;  |
| WSide        | I                | 0<br>1<br>2<br>3<br>4<br>5   |               | Wrap side<br>0 Both left & right sides<br>1 Left side<br>2 Right side<br>3 Side Towards Spine<br>4 Side Away from Spine<br>5 Largest Area  |
| Z-Index      | I                |  |               | The z-index of the graphic frame. Can be used to move a frame to the front/back. If the z-index is unknown, use any value like for example 0.  |

a.R=Required, I=Implied

## 4.7.1 LinePoint element



### LinePoint

| Attribute     | Def <sup>a</sup> | Value(s) | Default Value | Explanation/examples  |
|---------------|------------------|----------|---------------|---|
| AnchorPointX  | I                |          |               | The horizontal position of the anchor point in the specified units.         |
| AnchorPointY  | I                |          |               | The vertical position of the anchor point in the specified units.           |
| LeftDirPointX | R                |          |               | The horizontal position of the Left-direction point in the specified units. |
| LeftDirPointY | R                |          |               | The vertical position of the Left-direction point in the specified units.   |

## LinePoint (Continued)

| Attribute      | Def <sup>a</sup> | Value(s)         | Default Value | Explanation/examples  |
|----------------|------------------|------------------|---------------|---|
| PointType      | R                | kL<br>kCS<br>kCK |               | kL Line point<br>kCS Continuous smooth point<br>kCK Continuous unsmooth point |
| RightDirPointX | I                |                  |               | The horizontal position of the Right-direction point in the specified units.  |
| RightDirPointY | I                |                  |               | The vertical position of the Right-direction point in the specified units.    |

a.R=Required, I=Implied

## Chapter 5

### Content elements

This chapter describes the content elements that can be used within a text frame, table cell or Inline frame.

## 5.1 ParagraphStyle element

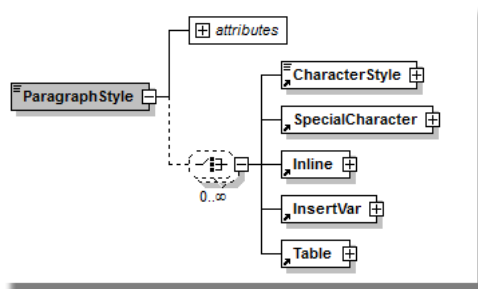

### ParagraphStyle

| Attribute | Def <sup>a</sup> | Value(s) | Default Value | Explanation/examples   |
|-----------|------------------|----------|---------------|--|
| Style     | R                |          |               | The style name that needs to be used to format this paragraph. |

a.R=Required, I=Implied

## 5.2 CharacterStyle element

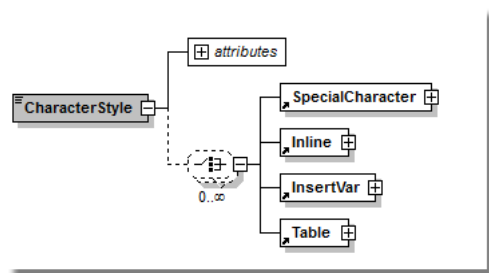

### CharacterStyle

| Attribute | Def <sup>a</sup> | Value(s) | Default Value | Explanation/examples   |
|-----------|------------------|----------|---------------|--|
| Style     | R                |          |               | The style name that needs to be used to format this set of characters. |

a.R=Required, I=Implied



## 5.3 SpecialCharacter element

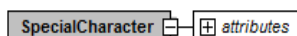

### SpecialCharacter

| Attribute | Def <sup>a</sup> | Value(s)   | Default Value | Explanation/examples   |
|-----------|------------------|--|---------------|--|
| Type      | R                | 3<br>7<br>8<br>9<br>10<br>24<br>25<br>160<br>173<br>8212<br>8211<br>8209<br>8193<br>8194<br>8195<br>8199<br>8200<br>8201<br>8202<br>1396927554 |               | 3 End nested style<br>7 Indent to here<br>8 Right aligned tab<br>9 Tab<br>10 Hard return (new paragraph)<br>24 Page numbers<br>25 Section marker<br>160 Nonbreaking space<br>173 Discretionary hyphen<br>8212 Em dash<br>8211 En dash<br>8209 Nonbreaking Hyphen<br>8193 Flush space<br>8194 En space<br>8195 Em space<br>8199 Figure space<br>8200 Punctuation space<br>8201 Thin space<br>8202 Hair space<br>1396927554 Column break |

a.R=Required, I=Implied

## 5.4 InsertVar element



### InsertVar

| Attribute | Def <sup>a</sup> | Value(s) | Def. value | Explanation/examples   |
|-----------|------------------|----------|------------|--|
| Name      |                  |          |            | Name of the variable. If the variable does not exist in the master, a new variable of the type "Custom Text" is created. If the variable exists (regardless of type) it is inserted in the content at the place where the InsertVar element is placed. |
| Value     |                  |          |            | Value of the variable (content). The value will only be set if the variable is of the type "Custom Text".  |

a.R=Required, I=Implied

### 5.4.1 Using the InsertVar element in a table of contents

Besides using the InsertVar element to insert variables in the content, you can also use the InsertVar element to generate a table of contents and/or index. To generate a table of contents, you need to publish the InsertVar element in the content and publish a corresponding InsertVar element in the table of contents. The source element will be used to determine the page number. The page number will be published at the location of the target variable.

In the content:

```
<InsertVar Name="TTOC_1" Value=""/>
```

In the table of contents:

```
<InsertVar Name="TOC_1" Value=""/>
```

Make sure the name of the source variable uses the prefix "TTOC\_" and the target variable uses the prefix "TOC\_". You can add any other value, for example "TTOC\_DOC\_1".

A basic XML could look like:

```
1 <?xml version="1.0" encoding="UTF-8" standalone="yes"?>
2 <Project Units="points" CloseProject="True">
3   <Books>
4     <Book BookFilename="" ExportPDF="False" PrintBook="False">
5       <Documents>
6         <Document Type="Dynamic" MasterFilename="" DocFilename="c:\temp\tests\TOC_test.indd" PageWidth="612.0000000000000000" PageHei
7           <Preferences SuperScriptPos="33.299999999999997" SuperScriptSize="58.299999999999997" SubScriptPos="33.299999999999997" Sul
8             <Colors>
94            <Styles>
125           <Layers>
133          <Pages>
134            <Page MasterPrefix="A" MasterBase="Master" Number="1">
135              <TextFrame Width="100" Height="100" X="80" Y="80" Z-Index="11">
136                <ParagraphStyle Style="P_ProductGroup">table of contents</ParagraphStyle>
137                <ParagraphStyle Style="Body">Title 1<SpecialCharacter Type="9"/><InsertVar Name="TOC_1" Value=""/></ParagraphStyle>
138                <ParagraphStyle Style="Body">Title 2<SpecialCharacter Type="9"/><InsertVar Name="TOC_2" Value=""/></ParagraphStyle>
139              </TextFrame>
140            </Page>
141            <Page MasterPrefix="A" MasterBase="Master" Number="2">
142              <TextFrame Width="150" Height="150" X="150" Y="150" Z-Index="11">
143                <ParagraphStyle Style="P_ProductGroup">source contents
144              </ParagraphStyle>
145              <ParagraphStyle Style="Body">This is the source title 1<InsertVar Name="TTOC_1" Value=""/></ParagraphStyle>
146              <ParagraphStyle Style="Body">This is the source title 2<InsertVar Name="TTOC_2" Value=""/></ParagraphStyle>
147            </TextFrame>
148          </Page>
149        </Pages>
150      </Document>
151    </Documents>
152  </Book>
153 </Books>
154 </Project>
155
```

This would generate a document with the first page:

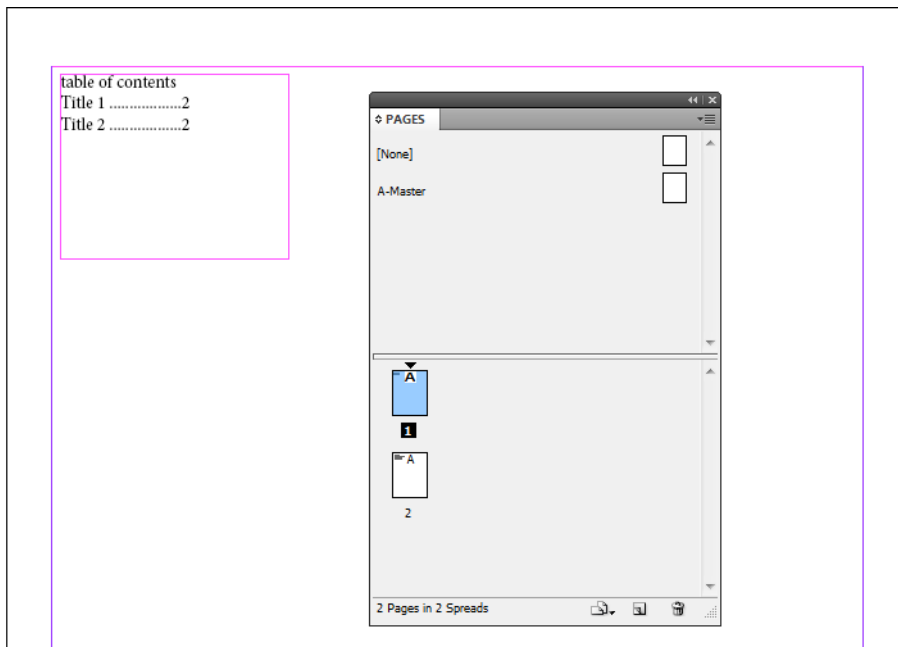

The second page (with the source content):

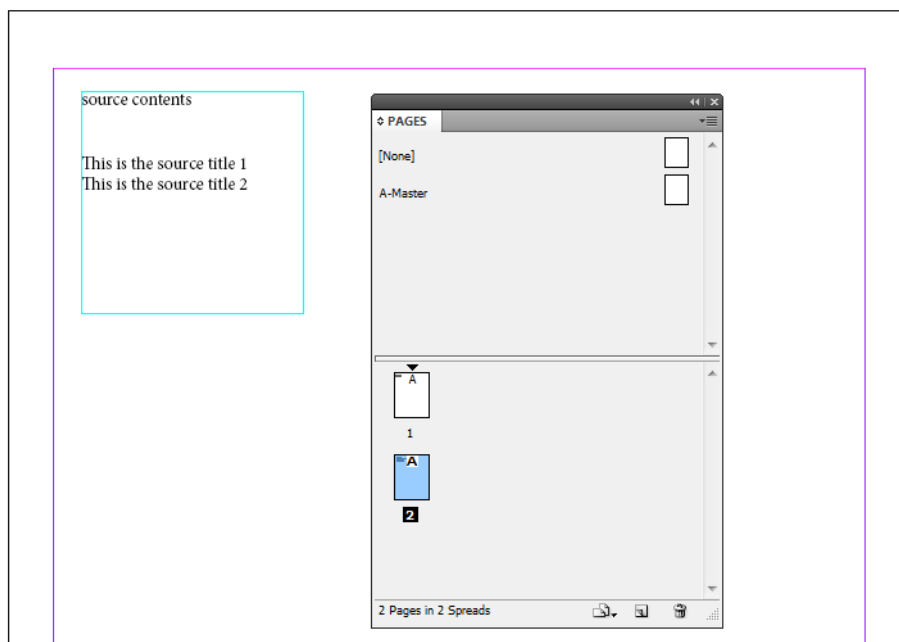

If you work with several documents in a book, you can use the same steps to publish a separate table of contents document inside the book.

A sample XML could look like:

```
4 <Book CreateBook="True" BookFilename="c:\temp\tests\TOCBook.indb" ExportPDF="False" PrintBook="False">
5 <Documents>
6 <Document Type="Dynamic" MasterFilename="c:\temp\tests\TOCmaster.indd" DocFilename="c:\temp\tests\TOC_test.indd" PageWidth="61:
7 <Preferences SuperScriptPos="33.299999999999997" SuperScriptSize="58.299999999999997" SubScriptPos="33.299999999999997" Sut
8 <Colors>
94 <Styles>
125 <Layers>
133 <Pages>
134 <Page MasterPrefix="A" MasterBase="Master" Number="1">
135 <TextFrame Width="100" Height="100" X="80" Y="80" Z-Index="11">
136 <ParagraphStyle Style="P_ProductGroup">table of contents</ParagraphStyle>
137 <ParagraphStyle Style="Body">Title 1<SpecialCharacter Type="9"/><InsertVar Name="TOC_1" Value=""/></ParagraphStyle>
138 <ParagraphStyle Style="Body">Title 2<SpecialCharacter Type="9"/><InsertVar Name="TOC_2" Value=""/></ParagraphStyle>
139 <ParagraphStyle Style="Body">Title 2<SpecialCharacter Type="9"/><InsertVar Name="TOC_3" Value=""/></ParagraphStyle>
140 <ParagraphStyle Style="Body">Title 2<SpecialCharacter Type="9"/><InsertVar Name="TOC_4" Value=""/></ParagraphStyle>
141 </TextFrame>
142 </Page>
143 </Pages>
144 </Document>
145 <Document Type="Dynamic" MasterFilename="c:\temp\tests\TOCmaster.indd" DocFilename="c:\temp\tests\TOC_content_test.indd" PageW
146 <Preferences SuperScriptPos="33.299999999999997" SuperScriptSize="58.299999999999997" SubScriptPos="33.299999999999997" Sut
147 <Colors>
233 <Styles>
264 <Layers>
272 <Pages>
273 <Page MasterPrefix="A" MasterBase="Master" Number="5">
274 <TextFrame Width="150" Height="150" X="150" Y="150" Z-Index="11">
275 <ParagraphStyle Style="P_ProductGroup">source contents
276 </ParagraphStyle>
277 <ParagraphStyle Style="Body">This is the source title 1<InsertVar Name="TTOC_1" Value=""/></ParagraphStyle>
278 <ParagraphStyle Style="Body">This is the source title 2<InsertVar Name="TTOC_2" Value=""/></ParagraphStyle>
279 </TextFrame>
280 </Page>
281 <Page MasterPrefix="A" MasterBase="Master" Number="">
282 <TextFrame Width="150" Height="150" X="150" Y="150" Z-Index="11">
283 <ParagraphStyle Style="P_ProductGroup">source contents
284 </ParagraphStyle>
285 <ParagraphStyle Style="Body">This is the source title 3<InsertVar Name="TTOC_3" Value=""/></ParagraphStyle>
286 <ParagraphStyle Style="Body">This is the source title 4<InsertVar Name="TTOC_4" Value=""/></ParagraphStyle>
287 </TextFrame>
288 </Page>
289 </Pages>
290 </Document>
291 </Documents>
292 </Book>
```

**Note**

Please note that the start number of the first page in the second document is set to 5 since we (for this example) want the first document to start on page number 5.

To set the numbering options, select the first page in the master document. Right-click and select

“Numbering & Section Options”:

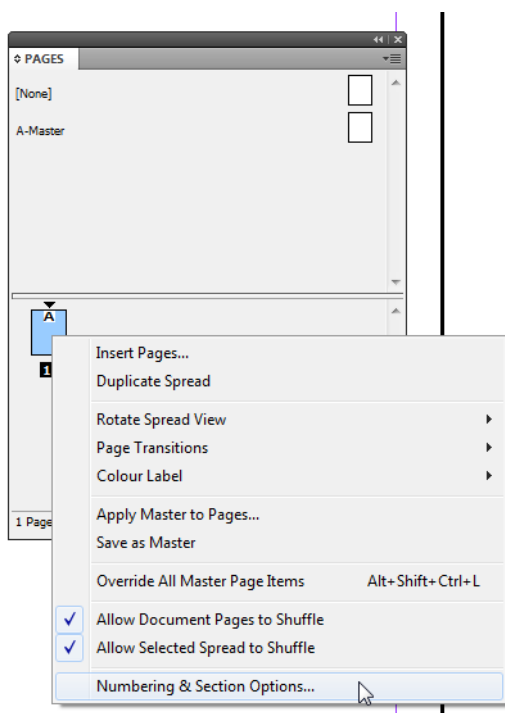

The “Numbering & Section Options” dialog is displayed:

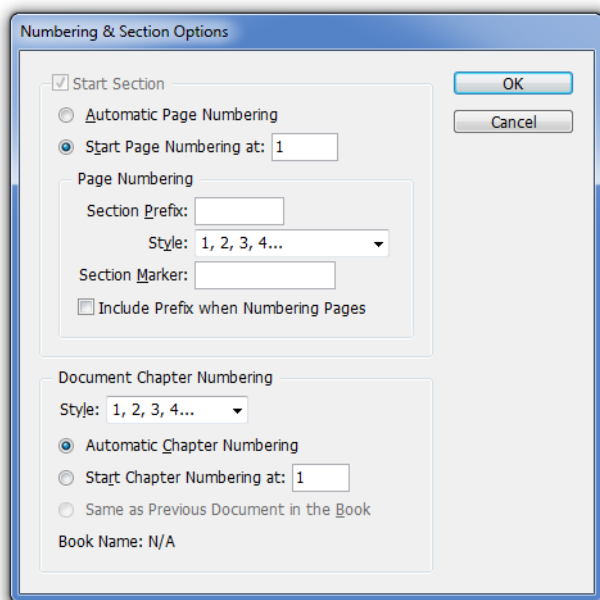

Select “Start Page Numbering at:” and set the value to 1. When the document is generated the start number will be set from the XML and in this case 1 will be set to 5.

This would produce a book file and two documents. This would look like:

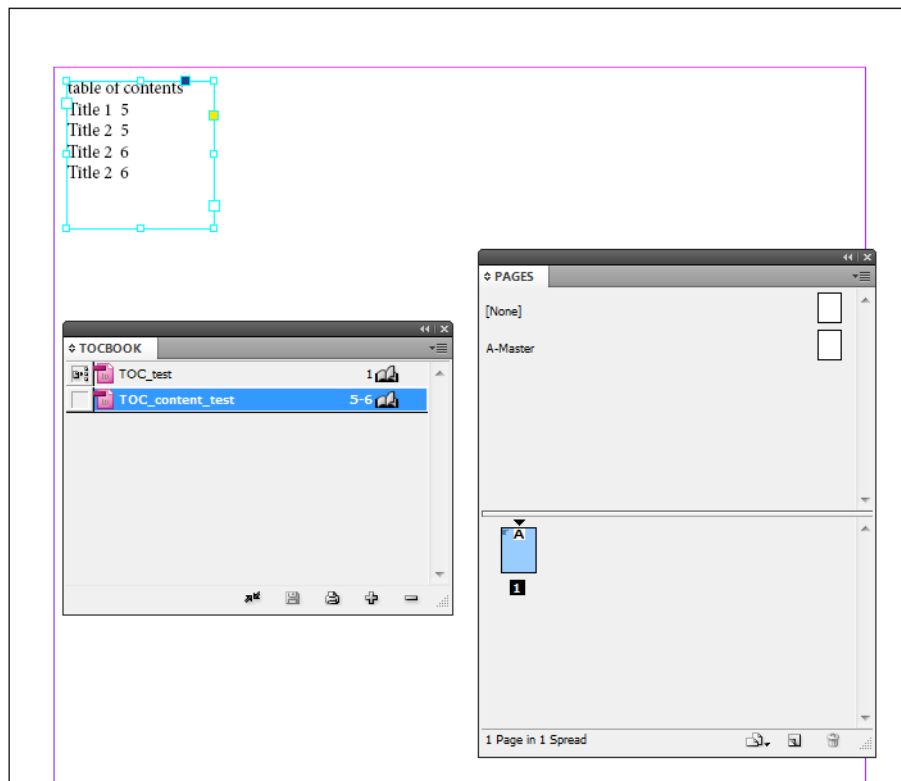

and:

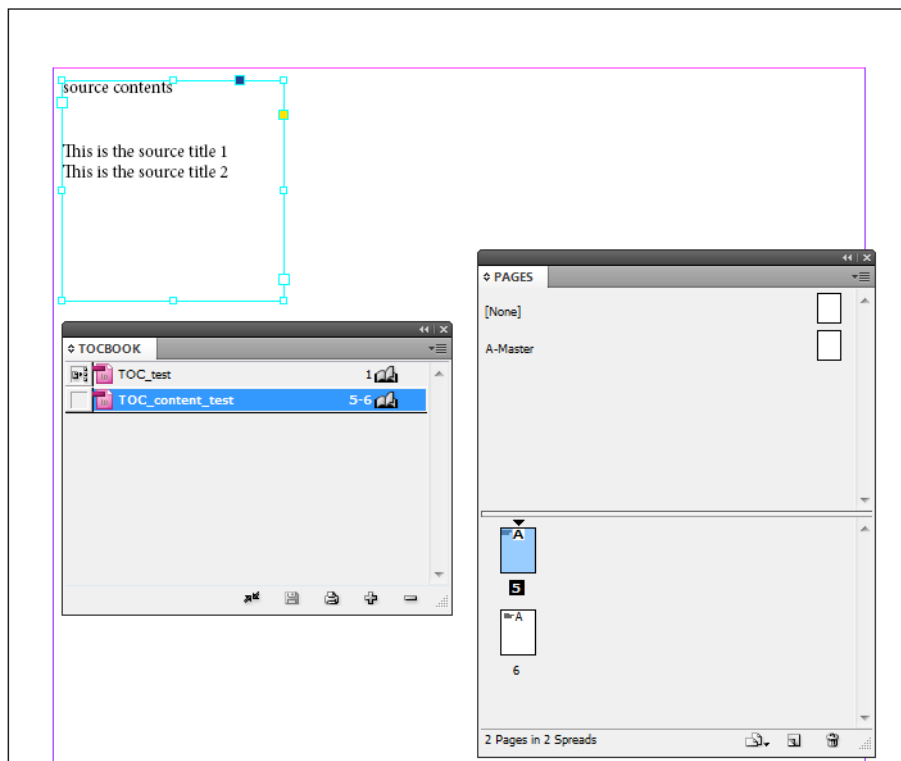

**Note**

Documents with facing Pages selected (left and right pages face each other in a double-page spread) that start with an even page number (Number attribute) begin on the left page. Odd-numbered pages are right-hand pages.

## 5.4.2 Using the InsertVar element in an index

To generate an index, you need to publish the InsertVar element in the content and you need to publish a corresponding InsertVar element in the index as well. The source element will then be used to determine the page number and the page number will be published at the location of the target variable.

In the content:

```
<InsertVar Name="TI_1" Value=""/>
```

In the index:

```
<InsertVar Name="I_1" Value=""/>
```

The index helps you to find information in long documents. Therefore you need several places in the content where variables correspond with an index variable.

A sample XML could look like:

```

1  <?xml version="1.0" encoding="UTF-8" standalone="yes"?>
2  <Project Units="mm">
3  <Books>
4  <Book CreateBook="True" BookFilename="c:\temp\tests\INXBook.indb" ExportPDF="False" PrintBook="False">
5  <Documents>
6  <Document Type="Dynamic" MasterFilename="c:\temp\tests\INXmaster.indd" DocFilename="c:\temp\tests\INX_content_test.indd" PageWid
7  <Pages>
8  <Page MasterPrefix="A" MasterBase="Master" Number="1">
9  <TextFrame Width="150" Height="150" X="150" Y="150" Z-Index="11">
10 <ParagraphStyle Style="P_ProductGroup">source contents
11 </ParagraphStyle>
12 <ParagraphStyle Style="Body">This is the source item 1<InsertVar Name="TI_0" Value=""/>
13 </ParagraphStyle>
14 <ParagraphStyle Style="Body">This is the source item 2<InsertVar Name="TI_1" Value=""/>
15 </ParagraphStyle>
16 </TextFrame>
17 </Page>
18 <Page MasterPrefix="A" MasterBase="Master" Number="">
19 <TextFrame Width="150" Height="150" X="150" Y="150" Z-Index="11">
20 <ParagraphStyle Style="P_ProductGroup">source contents
21 </ParagraphStyle>
22 <ParagraphStyle Style="Body">This is the source item 1<InsertVar Name="TI_0" Value=""/>
23 </ParagraphStyle>
24 <ParagraphStyle Style="Body">This is the source item 2<InsertVar Name="TI_2" Value=""/>
25 </ParagraphStyle>
26 </TextFrame>
27 </Page>
28 </Pages>
29 </Document>
30 <Document Type="Dynamic" MasterFilename="c:\temp\tests\INXmaster.indd" DocFilename="c:\temp\tests\INX_test.indd" PageWidth="612.1
31 <Pages>
32 <Page MasterPrefix="A" MasterBase="Master" Number="3">
33 <TextFrame Width="100" Height="100" X="80" Y="80" Z-Index="11">
34 <ParagraphStyle Style="P_ProductGroup">Index</ParagraphStyle>
35 <ParagraphStyle Style="Body">Item 1<SpecialCharacter Type="9"/>
36 <InsertVar Name="I_0" Value=""/>
37 </ParagraphStyle>
38 <ParagraphStyle Style="Body">Item 2<SpecialCharacter Type="9"/>
39 <InsertVar Name="I_1" Value=""/>
40 </ParagraphStyle>
41 </TextFrame>
42 </Page>
43 </Pages>
44 </Document>
45 </Documents>
46 </Book>
47 </Books>

```



In InDesign this would look like:

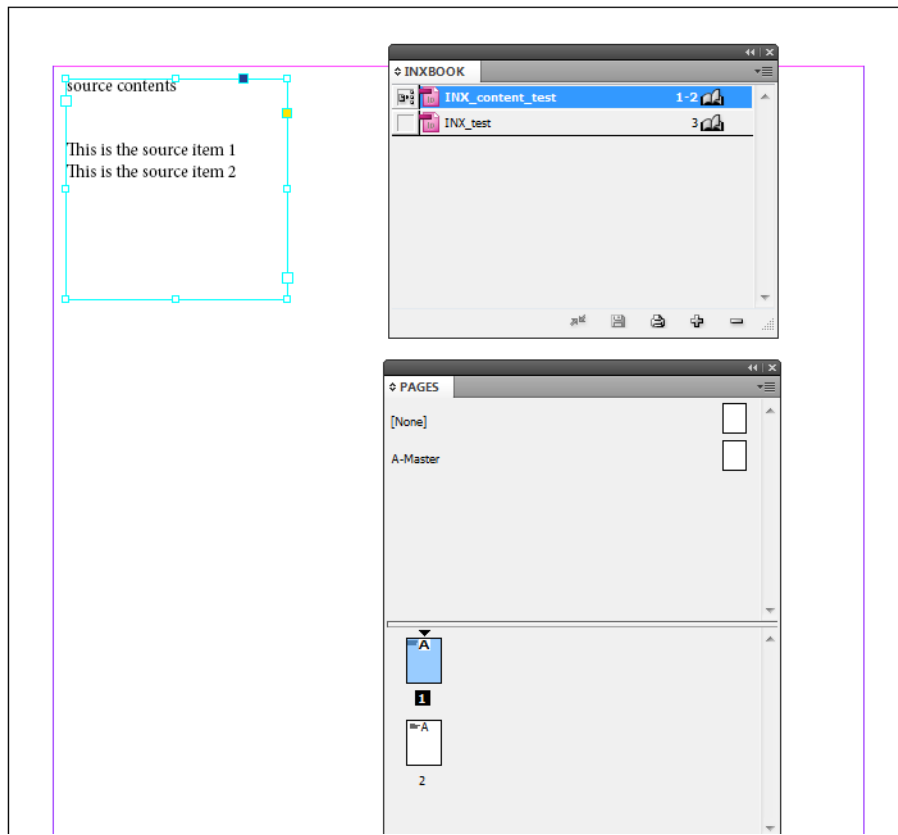

And in the index document:

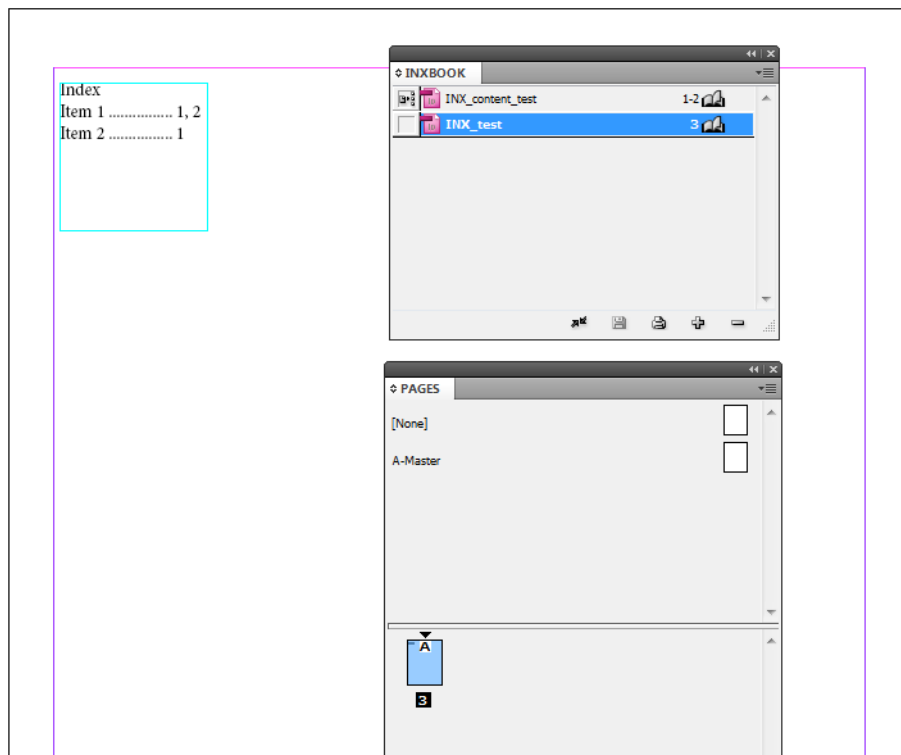

## Chapter 6

### Tables

This chapter describes the elements involved with creating InDesign tables

## 6.1 Table element

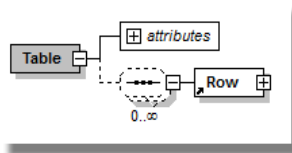

### Table

| Attribute    | Def <sup>a</sup> | Value(s)                                       | Def. value   | Explanation/examples   |
|--------------|------------------|--|--------------|--|
| TableStyle   | I                |  | 0            | The name of the table style to use for this table. If the style is not available in the master, the table style is created using defaults.   |
| ColCount     | I                |  |              | The number of columns. The default value is taken from the structure (number of cells in first row). If ColCount <= 0 -> then the table is not created. If ColCount value is less than the number of cells in the structure, then the number of cells out of structure taken over.<br><br><b>Be aware:</b><br>The number of columns always needs to be larger than 0 and can't be left empty. The number of columns also needs to correspond with the amount of cell elements for each row in the XML. |
| HeaderRows   | I                |  | 0            | The number of header rows. The RowCount includes the number of header rows. So for a table with 1 header row and 9 body rows the rowcount is 10.   |
| FooterRows   | I                |  | 0            | The number of footer rows. The RowCount includes the number of header rows. So for a table with 1 header row, 1 footer row and 8 body rows the rowcount is 9.  |
| RowCount     | I                |  |              | The number of rows. If left empty, the number of rows is determined based on the XML structure of the table.<br><br>The default value is taken from the structure (the number of rows of the table). If RowCount <= 0 -> then the table is not created. If RowCount value is less than the number of rows in the structure, the value taken over structure.  |
| RepeatHeader | I                | OncePerPage<br>OncePerFrame<br>EveryTextColumn | OncePerFrame | Sets the way the table header is repeated.   |
| RepeatFooter | I                | OncePerPage<br>OncePerFrame<br>EveryTextColumn | OncePerFrame | Sets the way the table footer is repeated.   |

a.R=Required, I=Implied

## 6.2 Row element

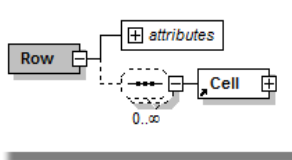

### Row

| Attribute | Def <sup>a</sup> | Value(s)            | Def. value | Explanation/examples                         |
|-----------|------------------|---------------------|------------|--|
| RowHeight | I                | AtLeast<br>Exactly) | AtLeast    | Sets the way the row height needs to be set. |
| RowMin    | I                |                     | 2          | The value is the minimum height of a row.    |
| RowMax    | I                |                     | 200        | The value is the maximum height of a row.    |

## Row

| Attribute    | Def <sup>a</sup> | Value(s)   | Def. value | Explanation/examples  |
|--------------|------------------|--|------------|---|
| StartRow     | I                | Anywhere<br>NextColumn<br>NextFrame<br>NextPage<br>NextOddPage<br>NextEvenPage | Anywhere   | Sets the way this row needs to be positioned.                       |
| KeepWithNext | I                | True<br>False  | False      | Set to True if the row needs to remain together with the row above. |

a.R=Required, I=Implied

## 6.3 Cell element

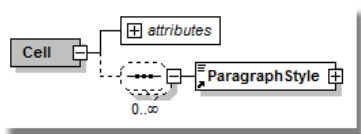

## Cell

| Attribute  | Def <sup>a</sup> | Value(s) | Def. value | Explanation/examples  |
|------------|------------------|----------|------------|---|
| CellStyle  | R                |          |            | The name of the cell style. If the cell style does not exist in the master document, it is created using defaults.  |
| ColWidth   | R                |          |            | The width of the column.  |
| HorStradle | R                |          |            | Value is horizontal stradle (stradle of columns: no stradle value is "0" when no value is inserted "0" is used default. Two columns stradle value is "1") |
| VerStradle | R                |          |            | Value is vertical stradle (stradle of rows: no stradle value is "0" when no value is inserted "0" is used default. Two rows stradle value is "1")         |

a.R=Required, I=Implied

The following example shows how to use the HorStradle attribute to merge the first three cells of the first row.

```

1  <?xml version="1.0" encoding="UTF-8"?>
2  <!DOCTYPE Table SYSTEM "D:\SourceCode\engine schema\PrintStu
3  <Table ColCount="" HeaderRows="" FooterRows="" TableStyle="">
4  <Row>
5  <Cell CellStyle="" ColWidth="" HorStradle="2" VerStradle=""/>
6  <Cell CellStyle="" ColWidth="" HorStradle="0" VerStradle=""/>
7  <Cell CellStyle="" ColWidth="" HorStradle="0" VerStradle=""/>
8  <Cell CellStyle="" ColWidth="" HorStradle="0" VerStradle=""/>
9  </Row>
10 <Row>
11 <Cell CellStyle="" ColWidth="" HorStradle="0" VerStradle=""/>
12 <Cell CellStyle="" ColWidth="" HorStradle="0" VerStradle=""/>
13 <Cell CellStyle="" ColWidth="" HorStradle="0" VerStradle=""/>
14 <Cell CellStyle="" ColWidth="" HorStradle="0" VerStradle=""/>
15 </Row>
16 </Table>
17
    
```

This will create the following table in InDesign:

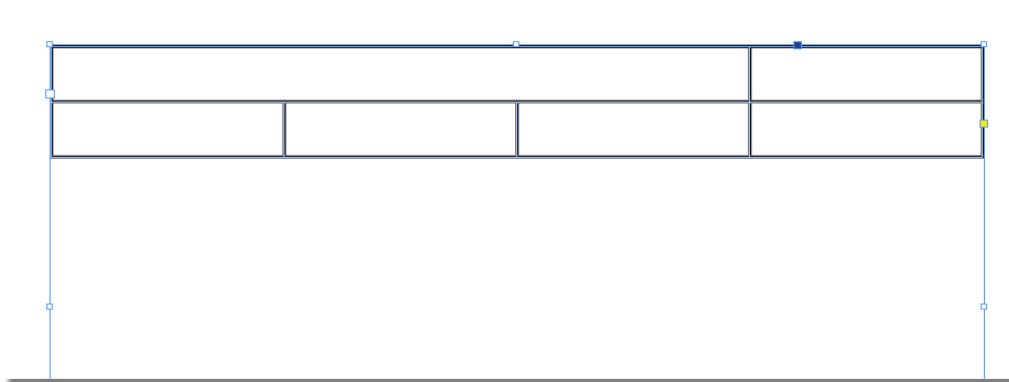

Be aware to use straddles correctly. If you create a row with 4 cells and stradle the first cell with the other 3 cells, this is basically a row with 1 cell.

## Chapter 7

### Inline frames

This chapter describes the elements involved with creating Inline frames.

## 7.1 Inline element

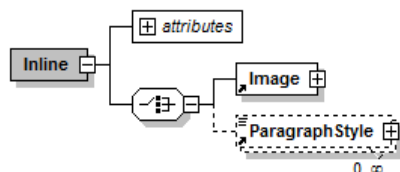

### Inline

| Attribute                | Def <sup>a</sup> | Value(s)  | Default Value | Explanation/examples  |
|--------------------------|------------------|---|---------------|---|
| Type                     | R                | Text<br>Graphic<br>Ellipse<br>Rectangle<br>Path                           | Text          | Text<br>Graphic<br>Ellipse<br>Rectangle<br>Path. Text frame<br>Graphic frame<br>Ellipse<br>Rectangle<br>Path.         |
| ParagraphStyle           | I                |   |               | Then type text is used the paragraph style to format the content can be set here.                                     |
| Height                   | R                |   |               | The height of the graphic frame in the specified units.   |
| Width                    | R                |   |               | The width of the graphic frame in the specified units.  |
| Position                 | R                | Inline<br>Aboveline   | Inline        | The position of the frame.  |
| YOffset                  | I                |   |               | Offset from baseline (for inline max. line height).   |
| XOffset                  | I                |   |               | Offset from   |
| Alignment                | I                | Left<br>Right<br>Center<br>TowardsSpine<br>AwayFromSpine<br>TextAlignment | Left          | The inline frame alignment.   |
| SpaceBefore              | I                |   |               | The space before an inline frame.   |
| PreventManualPositioning | I                | Yes<br>No   | No            | Yes means inline frames are locked and can not be changed manually<br>No means inline frames can be changed manually. |
| RelativeToSpine          | I                | Yes<br>No   | No            | The inline frame can be positioned relative to layout properties.   |
| AnchObjPtHor             | I                | Left<br>Center<br>Right   | Left          | The inline frame(Obj) can be anchored relative to horizontal layout properties.                                       |
| AnchObjPtVer             | I                | Top<br>Center<br>Bottom   | Top           | The inline frame(Obj) can be anchored relative to vertical layout properties.   |
| AnchPosPtHor             | I                | Left<br>Center<br>Right   | Left          | The inline frame(Pos) can be relative to horizontal layout properties.  |
| AnchPosPtVer             | I                | Top<br>Center<br>Bottom   | Top           | The inline frame(Pos) can be relative to vertical layout properties.  |
| XRelativeTo              | I                | AnchorMarker<br>ColumnEdge<br>TextFrame<br>PageMargin<br>PageEdge         | TextFrame     | The inline frame can be positioned relative to the X value.   |

## Inline (Continued)

| Attribute          | Def <sup>a</sup> | Value(s)   | Default Value | Explanation/examples  |
|--------------------|------------------|--|---------------|---|
| YRelativeTo        | I                | Baseline<br>LineCapHeight<br>LineTopLeading<br>ColumnEdge<br>TextFrame<br>PageMargin<br>PageEdge   | Baseline      | The inline frame can be positioned relative to the Y value.   |
| BottomTopBoundries | I                | Yes<br>No  | Yes           | Yes means inline frames are placed within the flow boundaries.<br>No means inline frames are placed within and without the flow boundaries. |
| Opacity            | I                | 0-100  |               | Integer<br>The opacity in percentage of the graphic frame.  |
| Transparency       | I                |  |               | The transparency of the graphic frame (as in Indesign).   |
| CornerRadius       | I                |  |               | The corner effects setting in the specified units of the graphic frame.   |
| CornerType         | I                |  |               | The corner effect setting of the graphic frame (as in Indesign).  |
| Name               | I                |  |               | Frame label (not used for now).   |
| Stroke             | I                |  |               | The stroke color in swatch or #rrggb or cmyk.<br>c=0;m=100;y=100;k=0;   |
| StrokeThickness    | I                |  |               | The thickness of the stroke in points.  |
| StrokeType         | I                | Solid<br>ThickThick<br>ThickThin<br>ThickThinThick<br>ThinThick<br>ThinThickThin<br>ThinThin<br>Triple_Stroke<br>Canned Dashed 3x2<br>Canned Dashed 4x4<br>Left Slant Hash<br>Right Slant Hash<br>Straight Hash<br>Canned Dotted<br>Wavy<br>White Diamond<br>Japanese Dots  Dashed). | Solid         | The type of stroke values.  |
| Rotation           | I                |  |               | The rotation of the graphic frame rotated round the centre middle. In degrees.  |
| Background         | I                |  |               | Background color in swatch or #rrggb or cmyk<br>c=0;m=100;y=100;k=0;  |
| margin-left        | I                |  |               | Left margin in the specified units.   |
| margin-top         | I                |  |               | Top margin in the specified units.  |
| margin-right       | I                |  |               | Right margin in the specified units.  |
| margin-bottom      | I                |  |               | Bottom margin in the specified units.   |
| VerticalAlignment  | I                | Top<br>Middle<br>Bottom<br>Justify   | Top           | The vertical alignment of the content in the frame when "Type" text is used.  |
| Id                 | I                |  |               | The automatic generated identifier for this object.   |
| Identifier         | I                |  |               | Can be used to specify an identifier for this object.   |
| SitecoreID         | I                |  |               | Only used in combination with Sitecore. Identifies Sitecore items created from InDesign objects.  |
| SitecoreFieldname  | I                |  |               | Only used in combination with Sitecore. Identifies Sitecore item fields used for creating InDesign objects.                                 |



**Inline (Continued)**

| Attribute       | Def <sup>a</sup> | Value(s)   | Default Value | Explanation/examples  |
|-----------------|------------------|--|---------------|---|
| Scaling         | I                | Fit Content to Frame<br>Fit Frame to Content<br>Center Content<br>Fit Content Proportionally<br>Fill Frame Proportionally<br>Fit Content Proportionally and Center |               | Images can be scaled automatically.   |
| HorizontalScale | I                |  |               | Value - / +   |
| VerticalScale   | I                |  |               | Value - / +   |
| Skew            | I                |  |               | Value in degrees.   |
| Center          | I                | True<br>False  | False         | False do nothing<br>True the image is placed as Indesign value "Center Content", attribute is used with scaling attributes (values).  |
| FitFrame        | I                | True<br>False  | False         | False do nothing<br>True the frame is placed as Indesign value "Fit frame to Content", attribute is used with scaling attributes (values).<br><br>When textual content, fit frame to content will only work when the number of columns is 1.      |
| ObjectStyle     | I                |  |               | An InDesign Object Style can be used for formatting (effects). If the name of the Object Style used in the master is used as value of this attribute it will be applied.  |
| FillTint        | I                |  |               | The percentage of the tint for the background color.  |
| StrokeTint      | I                |  |               | The percentage of the tint for the stroke color.  |
| WMode           | I                | 0<br>1<br>2<br>3<br>4<br>5<br>6<br>7<br>8  |               | Wrap mode<br>0 no text wrap<br>1 jump object<br>2 jump to next column<br>3 wrap around bounding box<br>4 Invalid, unimplemented<br>5 Invalid, unimplemented<br>6 wrap around object shape<br>7 Invalid, unimplemented<br>8 Invalid, unimplemented |
| WOffset         | I                | top;left;bottom;right;single   |               | Distance of wrap offset<br>Ex: 1;2;1;2;0;<br>Whether the item only supports one value for all sides (that is topMargin is the only valid margin) values 1/0.  |
| WInvert         | I                | 0<br>1   |               | Invert text wrap.   |
| WSide           | I                | 0<br>1<br>2<br>3<br>4<br>5   |               | Wrap side<br>0 both left & right sides<br>1 Left side<br>2 Right side<br>3 Side Towards Spine<br>4 Side Away from Spine<br>5 Largest Area)  |
| WIgnore         | I                | 1<br>0   |               | Ignore textwrap (only for text frames)<br>1 Ignore textwrap   |
| LCap            | I                | 0<br>1<br>2  |               | Line cap<br>0 But cap<br>1 Round cap<br>2 Projecting cap  |
| JType           | I                | 0<br>1<br>2  |               | Join type<br>0 Miter join<br>1 Round join<br>2 Bevel join   |
| MLim            | I                |  |               | Miter limit   |

**Inline (Continued)**

| Attribute | Def <sup>a</sup> | Value(s)  | Default Value | Explanation/examples  |
|-----------|------------------|---|---------------|---|
| SAlign    | I                | 0<br>1<br>2   |               | Stroke alignment<br>0 Align stroke to center<br>1 Align stroke to inside<br>2 Align stroke to outside |
| LEnd      | I                | Simple<br>Bar<br>SquareSolid<br>Square<br>CircleSolid<br>Circle<br>Curved<br>Barbed<br>TriangleWide<br>Triangle<br>SimpleWide |               | (Line end) and LStart (line start)  |
| BalCols   | I                | True/False  |               | Balance columns   |

a.R=Required, I=Implied

## Chapter 8

### Flow elements

Although most InDesign productions are page-oriented, the Engine also allows to produce more data driven productions. In this case pages are added if more space is needed to flow the content.

## 8.1 Flow element

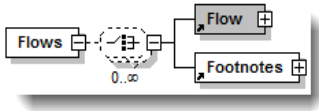

### Flow

| Attribute    | Def <sup>a</sup> | Value(s) | Def. value | Explanation/examples  |
|--------------|------------------|----------|------------|---|
| MasterPrefix |                  |          |            | For InDesign for example "A", "B" and so on.  |
| MasterBase   |                  |          |            | For InDesign for example "Master".  |
| Number       |                  |          |            | The number used to identify the page. If a page exists, the page objects are added to that specific page.<br>If the pages in the document are less than the number specified, the page is not shown in the PDF. The pages after the flow within the same document have to be auto numbered (left with no Number value). |

a.R=Required, I=Implied

When using a Flow type production, pages are automatically added when necessary. The content is placed automatically using a globally defined text frame. These text frames are fetched from the master page referred to by using the MasterPrefix and MasterBase attributes of the Flow element. Make sure your master pages contain these text frames and are placed in a layer called "flow". See the following example:

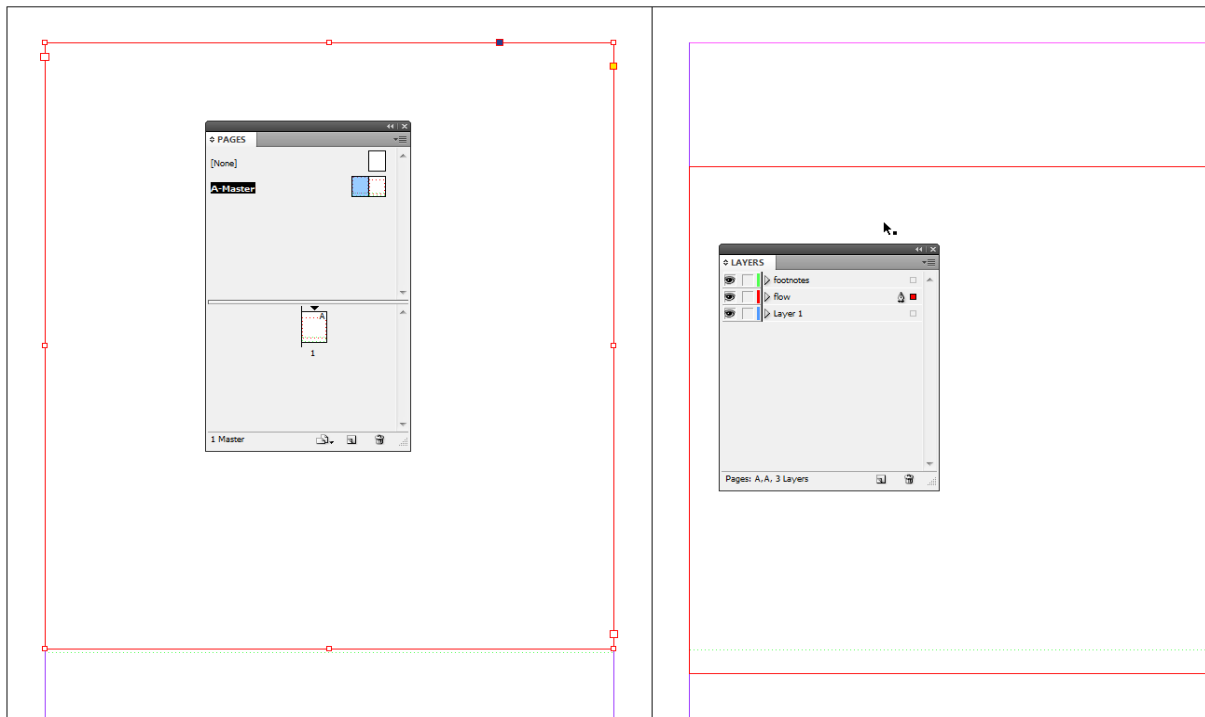

The very basic structure of a flow type production looks like:

```

1  <?xml version="1.0" encoding="UTF-8" standalone="yes"?>
2  <Project>
3  <Books>
4  <Book BookFilename="" ExportPDF="False" PrintBook="False">
5  <Documents>
6  <Document Type="Dynamic" MasterFilename="C:\temp\simpleDocMaster.indd" DocFilename="C:\temp\simpleDoc.indd">
7  <Pages>
8  <Flow MasterPrefix="A" MasterBase="Master">
9  <ParagraphStyle Style="BodyText">Some content</ParagraphStyle>
10 </Flow>
11 </Pages>
12 </Document>
13 </Documents>
14 </Book>
15 </Books>
16 </Project>
17
    
```

Or when combined with a page type production:

```

1  <?xml version="1.0" encoding="UTF-8" standalone="yes"?>
2  <Project>
3  <Books>
4  <Book BookFilename="" ExportPDF="False" PrintBook="False">
5  <Documents>
6  <Document Type="Dynamic" MasterFilename="C:\temp\simpleDocMaster.indd" DocFilename="C:\temp\simpleDoc.indd">
7  <Pages>
8  <Page MasterPrefix="A" MasterBase="Master" Number="1">
9  <Rectangle X="50" Y="50" Width="100" Height="100" Z-Index="1"/>
10 </Page>
11 <Page MasterPrefix="A" MasterBase="Master" Number="">
12 <Rectangle X="50" Y="50" Width="100" Height="100" Z-Index="1"/>
13 </Page>
14 <Flow MasterPrefix="A" MasterBase="Master">
15 <ParagraphStyle Style="BodyText">Some content</ParagraphStyle>
16 </Flow>
17 </Pages>
18 </Document>
19 </Documents>
20 </Book>
21 </Books>
22
    
```

## 8.2 Footnote element

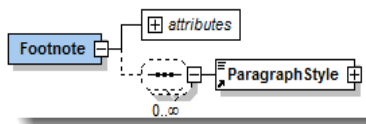

### Footnote

| Attribute  | Def <sup>a</sup> | Value(s)                | Def. value           | Explanation/examples   |
|------------|------------------|-------------------------|----------------------|--|
| Name       | R                |                         |                      | The name of the footnote used for matching, there must be an <InsertVar Name=""/> with the same name.  |
| AutoNumber | R                | True<br>False           | True                 | True the footnote will be numbered automatically according to selected value of the attribute type.  |
| Type       | R                | Numbers<br>Alphabetical | Numbers              | The selected type of numbering.  |
| Prefix     | R                |                         |                      | The characters set before the Number or Letter (alphabetical) for example Nr_ or Fn_   |
| Suffix     | R                |                         |                      | The characters set after the Number or Letter (alphabetical) for example 1 _Fn   |
| Style      | R                |                         | NoCharacterS<br>tyle | The style (character style) used for formatting the AutoNumber. The paragraph style set for the Footnote (and AutoNumber) is the style of the first paragraph style of Footnote. |

a.R=Required, I=Implied

The footnotes are defined in a general section (child of flows). Each footnote can be referenced in the content by inserting a variable (InsertVar element) that has a name that corresponds with the name of the footnote. The Engine will collect and publish all the referenced footnotes on the specific page.

The footnotes will be published inside a text frame that is globally defined on the master pages that are referenced for the flow. Make sure the master page has a text frame on a layer called “flow” as you can see in the following screenshot.

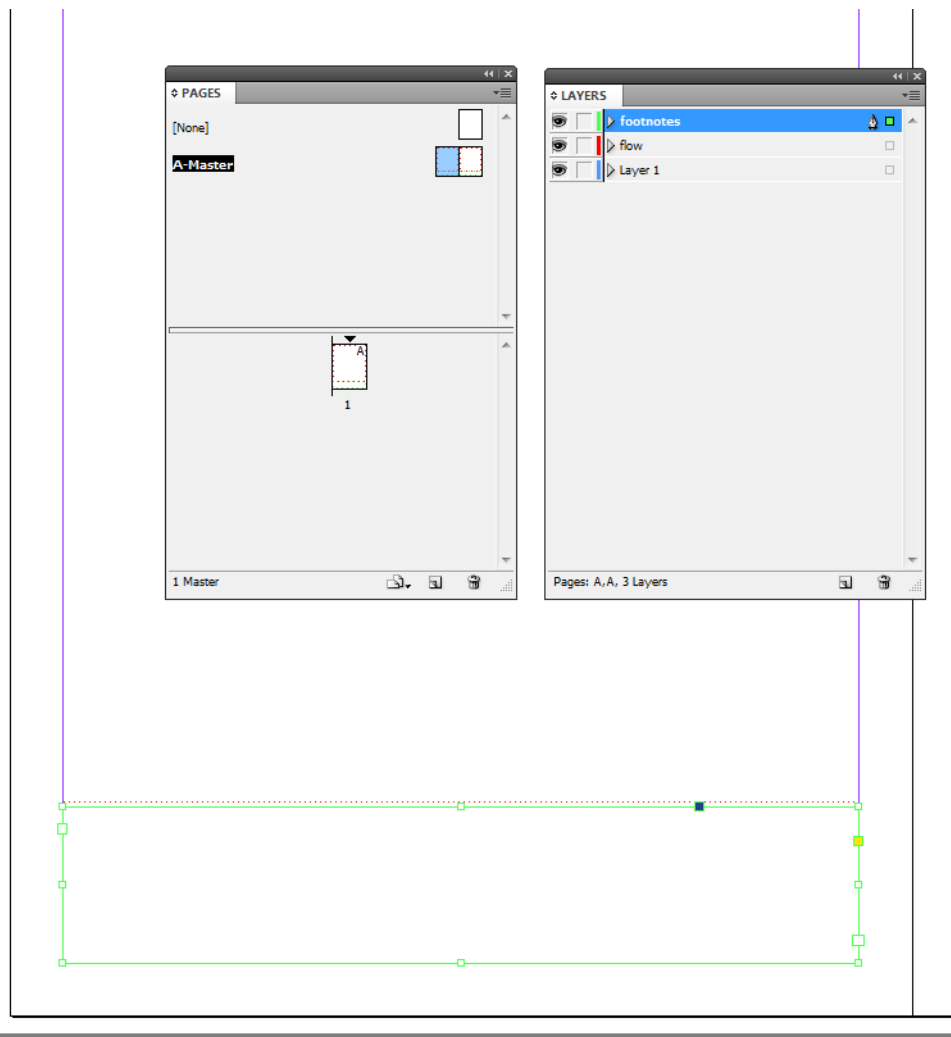

The basic XML structure looks like:

```

.xml version="1.0" encoding="UTF-8" standalone="yes"?>
project Units="points" CloseProject="True">
<Books>
  <Book BookFilename="" ExportPDF="False" PrintBook="False">
    <Documents>
      <Document Type="Dynamic" MasterFilename="C:\temp\tests\footnotemaster.indd" DocFilename="C:\temp\tests\output_test.indd" PageWidth="612.0000000000000000" PageHeight="792.0000000000000000">
        <Flows>
          <Footnotes>
            <Footnote Name="FN_1" Autonumber="False" Type="Numbers" Style="Super" Prefix="Nr." Suffix="...">
              <ParagraphStyle Style="NormalParagraphStyle"><![CDATA[footnote 1]]></ParagraphStyle>
            </Footnote>
            <Footnote Name="FN_2" Autonumber="True" Type="Numbers" Style="Super" Prefix="Nr." Suffix="...">
              <ParagraphStyle Style="NormalParagraphStyle"><![CDATA[footnote 2]]></ParagraphStyle>
            </Footnote>
            <Footnote Name="FN_3" Autonumber="True" Type="Alphabetical" Style="Super" Prefix="Nr." Suffix="...">
              <ParagraphStyle Style="NormalParagraphStyle"><![CDATA[footnote 3]]></ParagraphStyle>
            </Footnote>
          </Footnotes>
          <Flow MasterPrefix="A" MasterBase="Master">
            <ParagraphStyle Style="NormalParagraphStyle"><![CDATA[Some content]]><InsertVar Name="FN_1" Value=""/><![CDATA[]]></ParagraphStyle>
            <ParagraphStyle Style="NormalParagraphStyle"><![CDATA[More content]]><CharacterStyle Style="Super"><InsertVar Name="FN_2" Value=""/></CharacterStyle></ParagraphStyle>
            <ParagraphStyle Style="NormalParagraphStyle"><![CDATA[And even more content]]><InsertVar Name="FN_3" Value=""/></ParagraphStyle>
          </Flow>
        </Flows>
      </Document>
    </Documents>
  </Book>
</Books>
project>

```

This will create the following document:

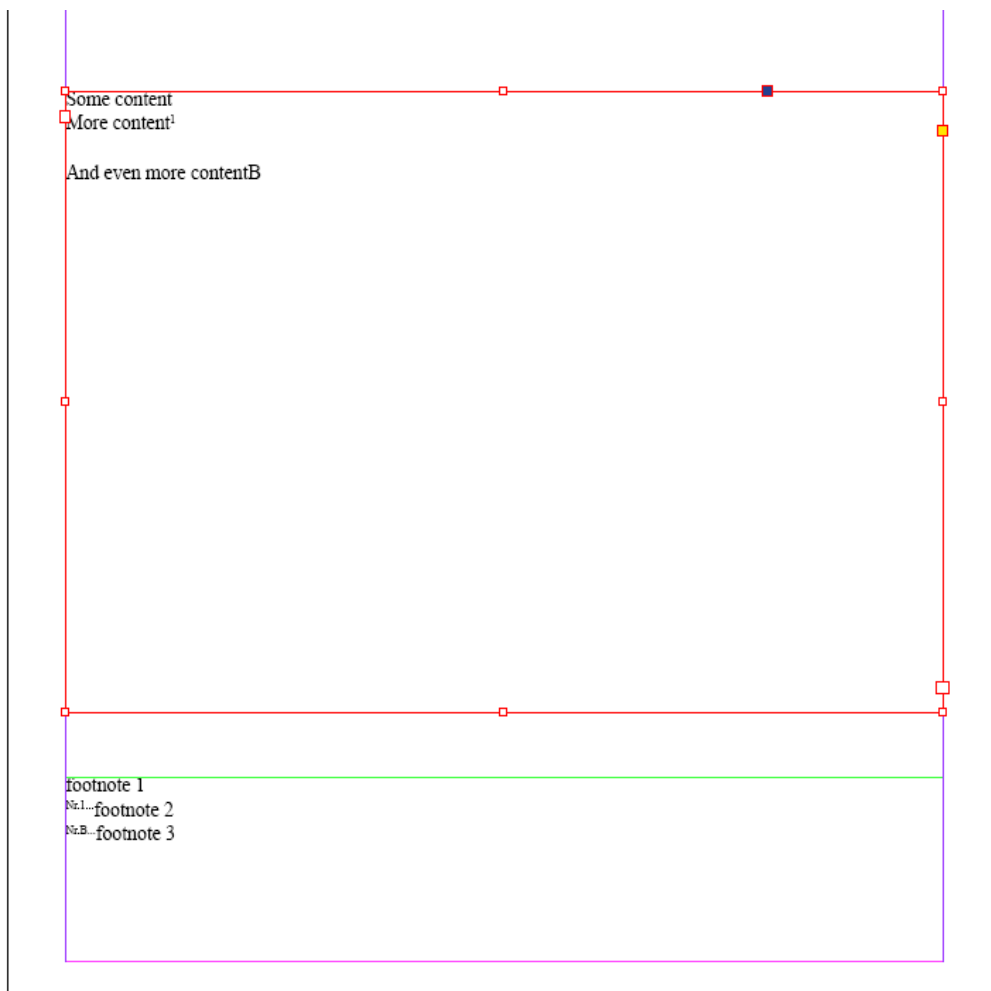

## Chapter 9

### Style elements

The style settings can be stored inside the master document. They can also be defined in XML. The XML values overrule the settings in the master. These style settings are documented here.



## 9.1 Preferences

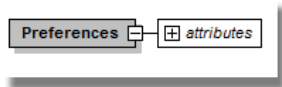

### Preferences

| Attribute       | Def <sup>a</sup> | Value(s) | Def. value | Explanation/examples |
|-----------------|------------------|----------|------------|----------------------|
| SuperScriptPos  | I                |          |            | In points            |
| SuperScriptSize | I                |          |            | In points            |
| SubScriptPos    | I                |          |            | In points            |
| SubScriptSize   | I                |          |            | In points            |

a.R=Required, I=Implied

## 9.2 Colors

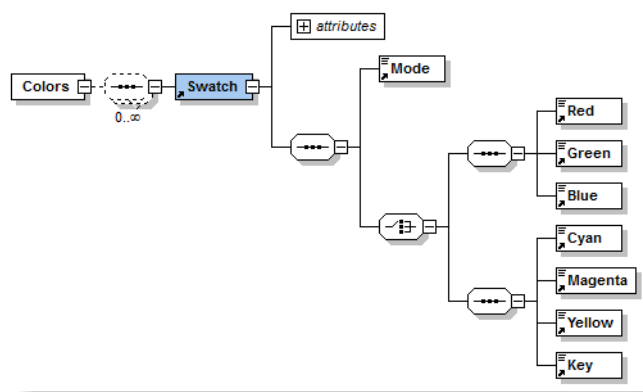

### Swatch

| Attribute | Def <sup>a</sup> | Value(s)    | Def. value | Explanation/examples   |
|-----------|------------------|-------------|------------|------------------------|
| Name      | R                |             |            | The name of the swatch |
| Mode      | R                | RGB<br>CMYK |            | Color mode             |
| Red       | R                | 0-255       |            | Integer                |
| Green     | R                | 0-255       |            | Integer                |
| Blue      | R                | 0-255       |            | Integer                |
| Cyan      | R                | 0-100       |            | Integer                |
| Magenta   | R                | 0-100       |            | Integer                |
| Yellow    | R                | 0-100       |            | Integer                |
| Key       | R                | 0-100       |            | Integer                |

a.R=Required, I=Implied

### 9.3 Layer element

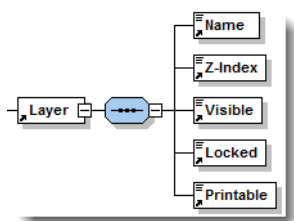

#### Layer

| Attribute | Def <sup>a</sup> | Value(s) | Def. value | Explanation/examples   |
|-----------|------------------|----------|------------|--|
| Name      | R                |          |            | The name of the layer. If it does not exist, it will be created.       |
| Z-Index   | R                |          |            | The z-index of this layer. If unknown, just use any value like 0 or 1. |
| Visible   | R                |          |            | The layer is visible or not.   |
| Locked    | R                |          |            | The layer is locked or not.  |
| Printable | R                |          |            | The layer is printable or not.   |

a.R=Required, I=Implied

### 9.4 Style elements

#### Character Styles/Paragraph/Table/Cell styles

| Attribute          | Def <sup>a</sup>           | Value(s)  | Default Value | Explanation/examples                           |
|--------------------|----------------------------|---|---------------|--|
| BalanceLines       |                            | True<br>False   |               | Balance ragged lines                           |
| BaselineShift      |                            |   |               | The BaselineShift.                             |
| BorderColor        |                            |   |               | Border color for table or cell styles.         |
| BorderGapColor     |                            |   |               | Border gap color for table or cell styles.     |
| BorderGapOverprint |                            |   |               | Border gap overprint for table or cell styles. |
| BorderGapTint      |                            |   |               | Border gap tint for table or cell styles.      |
| BorderOverprint    |                            |   |               | Border overprint for table or cell styles.     |
| BorderTint         |                            |   |               | Border tint for table or cell styles.          |
| BorderType         |                            |   |               | Border type for table or cell styles.          |
| BorderWeight       |                            |   |               | Border weight for table or cell styles.        |
| Bullets            |                            | BulletChar<br>TextAfter<br>CharStyle<br>Number<br>ContinueFromPrevious<br>StartAt         |               | The bullets for paragraph or character styles. |
| Case               |                            |   |               | The case for paragraph or character styles.    |
| CharacterColor     | R<br>R<br>R<br>R<br>R<br>R | FillOverprint<br>FillTint<br>StrokeColor<br>StrokeOverprint<br>StrokeTint<br>StrokeWeight |               | Used for the Character Color tab .             |
| Clipping           |                            |   |               | Clipping for table or cell styles.             |

## Character Styles/Paragraph/Table/Cell styles

| Attribute           | Def <sup>a</sup>   | Value(s)   | Default Value | Explanation/examples  |
|---------------------|--|--|---------------|---|
| ColumnStrokes       |  | FirstCount<br>FirstWeight<br>FirstType<br>FirstColor<br>FirstTint<br>FirstOverprint<br>FirstGapColor<br>FirstGapTint<br>FirstGapOverprint<br>NextCount<br>NextWeight<br>NextType<br>NextColor<br>NextTint<br>NextOverprint<br>NextGapColor<br>NextGapTint<br>NextGapOverprint<br>SkipFirst<br>SkipLast |               | The ColumnStrokes tab of the table styles.  |
| DiagnolColor        |  |  |               | Diagnol color type for table or cell styles.  |
| DiagnolGapColor     |  |  |               | Diagnol gap color for table or cell styles.   |
| DiagnolGapOverprint |  |  |               | Diagnol gap overprint for table or cell styles.   |
| DiagnolGapTint      |  |  |               | Diagnol gap tint for table or cell styles.  |
| DiagnolLine         |  |  |               | Diagnol line for table or cell styles.  |
| DiagnolOverprint    |  |  |               | Diagnol overprint for table or cell styles.   |
| DiagnolsOnTop       |  |  |               | Diagnols on top for table or cell styles.   |
| DiagnolStrokeType   |  |  |               | Diagnol stroke type for table or cell styles.   |
| DiagnolTint         |  |  |               | Diagnol tint for table or cell styles.  |
| DiagnolWeight       |  |  |               | Diagnol weight for table or cell styles.  |
| FillColor           |  |  |               | Fill color for table or cell styles.  |
| FillOverprint       |  |  |               | Fill overprint for table or cell styles.  |
| Fills               | R<br>R<br>R<br>R<br>R<br>R<br>R<br>R<br>R<br>R<br>R<br>R | Pattern<br>FirstCount<br>FirstColor<br>FirstTint<br>FirstOverprint<br>NextCount<br>NextColor<br>NextTint<br>NextOverprint<br>SkipFirst<br>SkipLast   |               | The Fills tab of the table styles.  |
| FillTint            |  |  |               | Fill tint for table or cell styles.   |
| FirstBaselineMin    |  |  |               | First baseline minimum for table or cell styles.  |
| FirstBaselineOffset |  |  |               | First baseline offset for table or cell styles.   |
| FirstLineIndent     |  |  |               | The indent for the first line.  |
| FontColor           |  |  |               | The font color for paragraph or character styles. The hex. Value of the RGB color values (for example #29292D) or the name of a swatch. |
| FontFamily          |  |  |               | The name of the font family for paragraph or character styles.  |
| FontSize            |  |  |               | The font size (points) for paragraph or character styles.   |
| FontStyle           |  |  |               | The font style for paragraph or character styles.   |
| HorizontalAlignment |  |  |               | The horizontal alignment for paragraph or character styles.   |
| HorizontalScale     |  |  |               | The HorizontalScale (Advanced Character Formats).   |

## Character Styles/Paragraph/Table/Cell styles

| Attribute      | Def <sup>a</sup>  | Value(s)   | Default Value | Explanation/examples                                  |
|----------------|---|--|---------------|---|
| Hyphenation    | R<br>R<br>R<br>R<br>R<br>R<br>R<br>R<br>R<br>R  | Capitalized<br>Ladder<br>LastWord<br>Limit<br>Zone<br>CrossColumn<br>AfterFirst<br>BeforeLast<br>ShortestWord<br>Mode  |               | Used for the Hyphenation tab.                         |
| InsetBottom    |   |  |               | Inset bottom for table or cell styles.                |
| InsetLeft      |   |  |               | Inset left for table or cell styles.                  |
| InsetRight     |   |  |               | Inset right for table or cell styles.                 |
| InsetTop       |   |  |               | Inset top for table or cell styles.                   |
| Justification  | R<br>R<br>R<br>R<br>R<br>R<br>R<br>R<br>R<br>R<br>R   | WordSpaceMin<br>WordSpaceMax<br>WordSpaceDes<br>GlyphsScaleMin<br>GlyphsScaleMax<br>GlyphsScaleDes<br>LetterSpaceMin<br>LetterSpaceMax<br>LetterSpaceDes<br>AutoLeading<br>SingleWordJustification   |               | Used for the Justification tab.                       |
| Kerning        |   |  |               | The Kerning (Basic Character Formats).                |
| Language       |   | See note at the end of this table  |               | The language used for determining hyphens.            |
| LastLineIndent |   |  |               | The indent for the last line.                         |
| Leader         | R   | CharValue  |               |   |
| LeftIndent     |   |  |               | The left indent for paragraph or character styles.    |
| LetterSpacing  |   |  |               | The letter spacing for paragraph or character styles. |
| Ligatures      |   |  |               | The Ligatures (Basic Character Formats).              |
| LineHeight     |   |  |               | The line height for paragraph or character styles.    |
| NoBreak        |   |  |               | The No Break (Basic Character Formats).               |
| Position       |   |  |               | The position for paragraph or character style         |
| RightIndent    |   |  |               | The right indent for paragraph or character styles.   |
| RowStrokes     | R<br>R<br>R<br>R<br>R<br>R<br>R<br>R<br>R<br>R<br>R<br>R<br>R<br>R<br>R<br>R<br>R<br>R<br>R<br>R<br>R<br>R<br>R | FirstCount<br>FirstWeight<br>FirstType<br>FirstColor<br>FirstTint<br>FirstOverprint<br>FirstGapColor<br>FirstGapTint<br>FirstGapOverprint<br>NextCount<br>NextWeight<br>NextType<br>NextColor<br>NextTint<br>NextOverprint<br>NextGapColor<br>NextGapTint<br>NextGapOverprint<br>SkipFirst<br>SkipLast |               | The RowStrokes tab of the table styles.               |

## Character Styles/Paragraph/Table/Cell styles

| Attribute          | Def <sup>a</sup>  | Value(s)   | Default Value | Explanation/examples   |
|--------------------|---|--|---------------|--|
| RuleAbove          | R<br>R<br>R<br>R<br>R<br>R<br>R<br>R<br>R<br>R<br>R<br>R<br>R | RuleOn<br>StrokeWeight<br>StrokeType<br>StrokeColor<br>StrokeTint<br>StrokeOverprint<br>GapColor<br>GapTint<br>GapOverprint<br>Width<br>Offset<br>LeftIndent<br>RightIndent<br>KeepInFrame |               | The ParagraphRules tab of the paragraph styles.  |
| RuleBelow          | R<br>R<br>R<br>R<br>R<br>R<br>R<br>R<br>R<br>R<br>R<br>R<br>R | RuleOn<br>StrokeWeight<br>StrokeType<br>StrokeColor<br>StrokeTint<br>StrokeOverprint<br>GapColor<br>GapTint<br>GapOverprint<br>Width<br>Offset<br>LeftIndent<br>RightIndent                |               | The ParagraphRules tab of the paragraph styles.  |
| SkewAngle          |   |  |               | The skew angle for the characters.   |
| SpaceAfter         |   |  |               | Space after table for table styles.  |
| SpaceBefore        |   |  |               | Space before table for table styles.   |
| Strikethrough      | R<br>R<br>R<br>R<br>R<br>R<br>R<br>R<br>R                     | Weight<br>Type<br>Offset<br>Color<br>Tint<br>StrokeOverprint<br>GapColor<br>GapTint<br>GapOverprint  |               | Strike through yes or no for paragraph or character styles.  |
| StrokeColor        | R<br>R<br>R<br>R  | Left<br>Top<br>Right<br>Bottom   |               | Stroke Color for table or cell styles. When value is inserted for element this will overrule the values set with the attributes.       |
| StrokeGapColor     | R<br>R<br>R<br>R  | Left<br>Top<br>Right<br>Bottom   |               | StrokeGapColor for table or cell styles. When value is inserted for element this will overrule the values set with the attributes.     |
| StrokeGapOverprint | R<br>R<br>R<br>R  | Left<br>Top<br>Right<br>Bottom   |               | StrokeGapOverprint for table or cell styles. When value is inserted for element this will overrule the values set with the attributes. |
| StrokeGapTint      | R<br>R<br>R<br>R  | Left<br>Top<br>Right<br>Bottom   |               | StrokeGapTint for table or cell styles. When value is inserted for element this will overrule the values set with the attributes.      |
| StrokeOverprint    | R<br>R<br>R<br>R  | Left<br>Top<br>Right<br>Bottom   |               | StrokeOverprint for table or cell styles. When value is inserted for element this will overrule the values set with the attributes.    |
| StrokeTint         | R<br>R<br>R<br>R  | Left<br>Top<br>Right<br>Bottom   |               | StrokeTint for table or cell styles. When value is inserted for element this will overrule the values set with the attributes.         |
| StrokeType         | R<br>R<br>R<br>R  | Left<br>Top<br>Right<br>Bottom   |               | Stroke type for table or cell styles. When value is inserted for element this will overrule the values set with the attributes.        |

## Character Styles/Paragraph/Table/Cell styles

| Attribute             | Def <sup>a</sup>                          | Value(s)  | Default Value | Explanation/examples  |
|-----------------------|---|---|---------------|---|
| StrokeWeight          | R<br>R<br>R<br>R                          | Left<br>Top<br>Right<br>Bottom  |               | Stroke weight for table or cell styles. When value is inserted for element this will overrule the values set with the attributes. |
| Tab (Leader?)         | R<br>R<br>R<br>R                          | LeaderCount<br>Alignment<br>AlignToChar<br>Position   |               |   |
| Tabs (Tab)            |   |   |               | For the Tabs tab.   |
| TextRotation          |   |   |               | Text rotation for table or cell styles.   |
| Tracking              |   |   |               | The tracking (Basic Character Formats).   |
| Underline             | R<br>R<br>R<br>R<br>R<br>R<br>R<br>R<br>R | Weight<br>Type<br>Offset<br>Color<br>Tint<br>StrokeOverprint<br>GapColor<br>GapTint<br>GapOverprint |               | Underline yes or no for paragraph or character styles.  |
| VerticalJustification |   |   |               | Vertical justification for table or cell styles.  |
| VerticalScale         |   |   |               | The VerticalScale (Advanced Character Formats).   |
| VJSpacingLimit        |   |   |               | Vertical justification spacing limit for table or cell styles.  |

a.R=Required, I=Implied

### Language values

| Language in InDesign | Internal value to use in XML |
|----------------------|------------------------------|
|----------------------|------------------------------|

|                      |                      |
|----------------------|----------------------|
| English UK:          | English: UK          |
| Bulgarian:           | Bulgarian            |
| Catalan:             | Catalan              |
| Croatian:            | Croatian             |
| Czech:               | Czech                |
| Danish:              | Danish               |
| Dutch: 2005 Reform   | n1_NL_2005           |
| Dutch: Old Rules:    | Dutch                |
| English Canadian:    | English: Canadian    |
| English USA          | English: USA         |
| English: USA Legal   | English: USA Legal   |
| English: USA Medical | English: USA Medical |
| Estonian             | Estonian             |
| Finnish              | Finnish              |
| French               | French               |
| French: Canadian     | French: Canadian     |
| German: Reformed     | German: Reformed     |
| German 2006 Reform   | de_DE_2006           |
| German Old Rules     | German: Traditional  |

|                                       |                        |
|---------------------------------------|------------------------|
| German: Swiss                         | German: Swiss          |
| German: Swiss 2006 Reform             | de_CH_2006             |
| Greek                                 | Greek                  |
| Hungarian                             | Hungarian              |
| Italian                               | Italian                |
| Latvian                               | Latvian                |
| Lithuanian                            | Lithuanian             |
| Norwegian: Bokmal                     | Norwegian: Bokmal      |
| Norwegian: Nynorsk                    | Norwegian: Nynorsk     |
| Polish                                | Polish                 |
| Portuguese: Orthographic: Portuguese: | Orthographic Agreement |
| Portuguese                            | Portuguese             |
| Portuguese: Brazilian                 | Portuguese: Brazilian  |
| Romanian                              | Romanian               |
| Russian                               | Russian                |
| Slovak                                | Slovak                 |
| Slovenian                             | Slovenian              |
| Spanish                               | Spanish: Castilian     |
| Swedish                               | Swedish                |
| Turkish                               | Turkish                |
| Ukrainian                             | Ukrainian              |

## Chapter 10

### Special elements

This chapter describes special elements.



## 10.1 Variable element

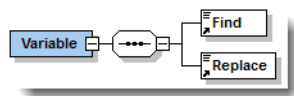

### Variable

| Attribute | Def <sup>a</sup> | Value(s) | Default Value | Explanation/examples |
|-----------|------------------|----------|---------------|----------------------|
| Find      |                  |          |               | Find value           |
| Replace   |                  |          |               | Replace with value   |

a.R=Required, I=Implied

The variable element allows you to set the variable contents (variable of the type “Custom Text”). Be aware that it does not create a variable if it does not exist in the master document, it only sets the content. To create a variable in the master document, select **Type, Text Variables, Define** from the InDesign main menu:

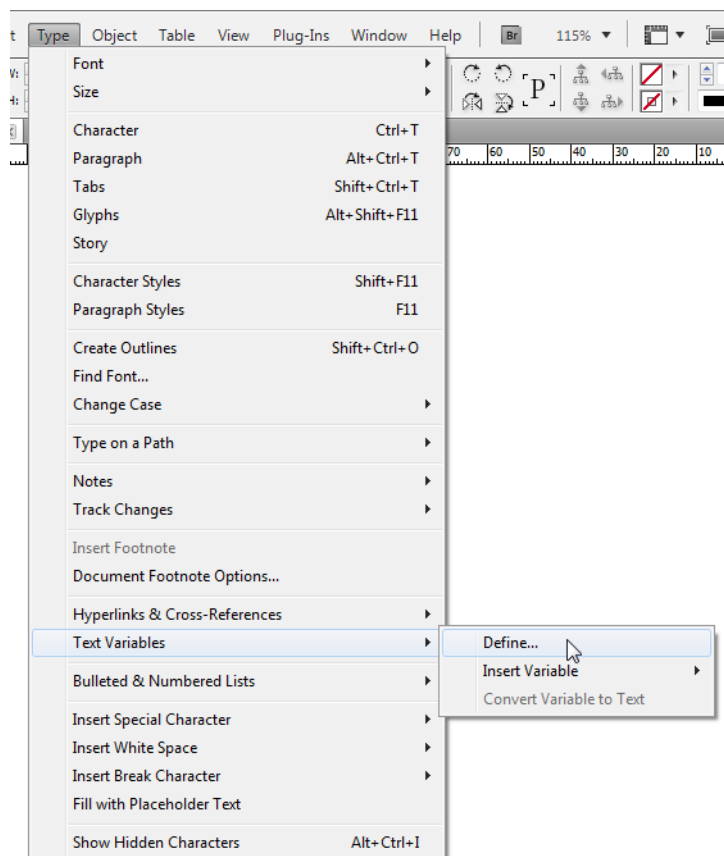

The **Text Variables** dialog is displayed:

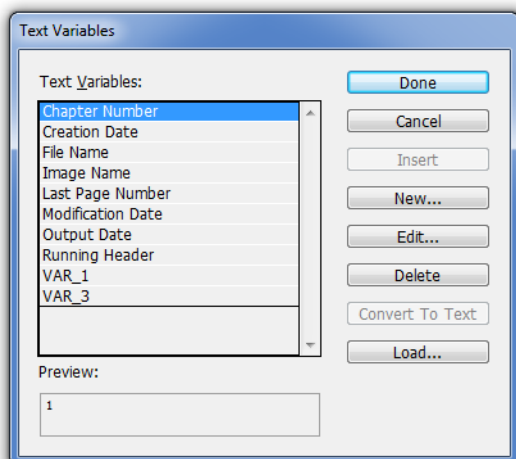

Click **New**. The “New Text Variable” is displayed:

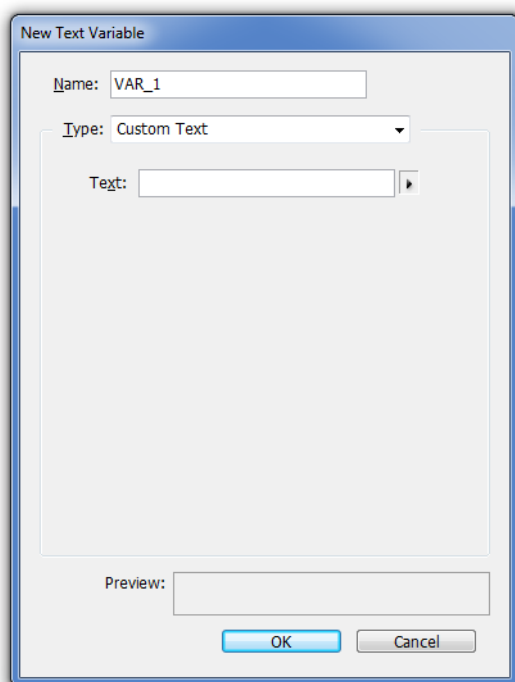

Select the **Custom Text** as a type and fill in the **Name** field with the value that corresponds to the name value of your **Find** element in the XML.

```

<Variables>
  <Variable>
    <Find>VAR_1</Find>
    <Replace>this is VAR_1</Replace>
  </Variable>
</Variables>
    
```

A variable can be inserted in the content by using the **InsertVar** element. To illustrate how both work together:

```

1  <?xml version="1.0" encoding="UTF-8" standalone="yes"?>
2  <Project>
3  <Books>
4  <Book BookFilename="" ExportPDF="False" PrintBook="False">
5  <Documents>
6  <Document Type="Dynamic" MasterFilename="c:\temptests\VARSmaster.indd" DocFilename="c:\temptests\VAR_S_test.indd" PageWidthI
7  <Variables>
8  <Variable>
9  <Find>VAR_1</Find>
10 <Replace>this is VAR_1</Replace>
11 </Variable>
12 </Variables>
13 <Pages>
14 <Page MasterPrefix="A" MasterBase="Master" Number="3">
15 <TextFrame Width="200" Height="200" X="120" Y="120" Z-Index="0">
16 <ParagraphStyle Style="P_ProductGroup">Some content</ParagraphStyle>
17 <ParagraphStyle Style="Body">create var in content: <InsertVar Name="VAR_3" Value="this is VAR_3"/></ParagraphStyle>
18 <ParagraphStyle Style="Body">use var 1: <InsertVar Name="VAR_1" Value=""/></ParagraphStyle>
19 <ParagraphStyle Style="Body">and var 3 again: <InsertVar Name="VAR_3" Value=""/></ParagraphStyle>
20 <ParagraphStyle Style="Body">creation date var: <InsertVar Name="VAR_X" Value=""/></ParagraphStyle>
21 <ParagraphStyle Style="Body">other var: <InsertVar Name="VAR_X1" Value="test"/></ParagraphStyle>
22 </TextFrame>
23 </Page>
24 </Pages>
25 </Document>
26 </Documents>
27 </Book>
28 </Books>
29 </Project>
30
    
```

In this sample XML we set the value of the VAR\_1 variable to “this is VAR\_1”. In the content we use the “InsertVar” element to create a new variable called “VAR\_3”. We then insert the variable “VAR\_1”. Then we insert the “VAR\_3”. Then we insert the variable “VAR\_X”, which corresponds to a variable of the type “Creation date” in the master. And finally we create a new variable called “VAR\_X1” and set the value of that variable to “test”.

This would result in:

